

TM

Alfresco™

Open Air Culinary Systems

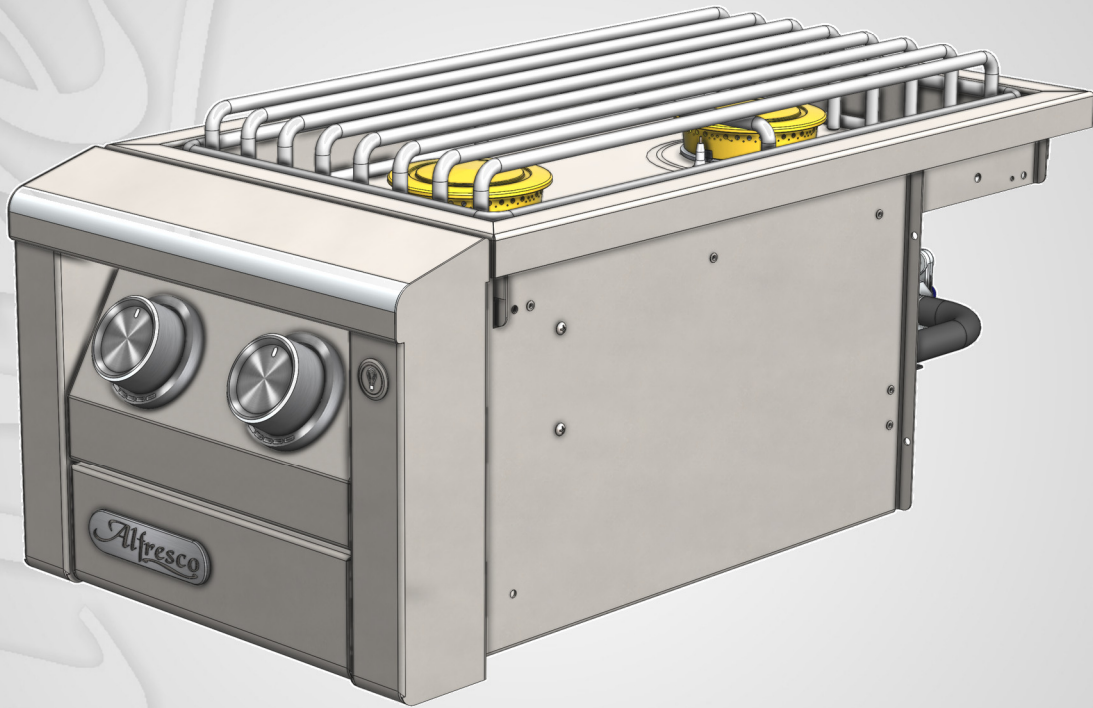

AIPGSB-2 SIDE BURNER CARE AND USE MANUAL



1085 Bixby Drive
City of Industry, CA. 91745
(888) 383-8800
www.alfrescogrills.com

INSTALLER: Leave these instructions with the consumer.
CONSUMER: Retain these instructions for future reference.

DANGER

IF YOU SMELL GAS:

1. SHUT OFF GAS TO THE APPLIANCE
2. EXTINGUISH ANY OPEN FLAME.
3. OPEN LID.
4. IF ODOR CONTINUES, KEEP AWAY FROM THE APPLIANCE AND IMMEDIATELY CALL YOUR GAS SUPPLIER AND OR FIRE DEPARTMENT.

WARNING

1. DO NOT STORE OR USE GASOLINE OR OTHER FLAMMABLE LIQUIDS OR VAPORS IN THE VICINITY OF THIS OR ANY OTHER APPLIANCE.
2. AN LP CYLINDER NOT CONNECTED FOR USE SHALL NOT BE STORED IN THE VICINITY OF THIS OR ANY OTHER APPLIANCE.

DANGER

S'IL Y A UNE ODEUR DE GAZ:

1. COUPEZ L'ADMISSION DE GAZ DE L'APPAREIL.
2. ÉTENDRE TOUTE FLAME NUE.
3. OUVRIR LE COURVERCLE.
4. SI L'ODEUR PERSISTE, ÉLOIGNEZ-VOUS DE L'APPAREIL ET APPELEZ IMMÉDIATEMENT LE FOURNISSEUR DE GAZ OU LE SERVICE D'IN-

AVERTISSEMENT

1. NE PAS ENTREPOSER NI UTILISER DE L'ESSENCE NI D'AUTRES VAPEURS OU LIQUIDES INFLAMMABLES À PROXIMITÉ DE CET APPAREIL NI DE TOUT AUTRE APPAREIL.
2. UNE BOUTEILLE DE GPL QUI N'EST PAS RACCORDEE EN VUE DE SON UTILISATION NE DOIT PAS ÊTRE ENTREPOSÉE À PROXIMITÉ E CET APPAREIL NI DE TOUT AUTRE APPAREIL.

TESTED IN ACCORDANCE WITH: ANSI Z21.58-2022 AND CSA 1.6-2022

THE STANDARD FOR OUTDOOR COOKING GAS APPLIANCES.

CODE REQUIREMENTS:

Installation of this cooking appliance must conform to local codes. In the absence of local codes, this unit should be installed in accordance with the *National Fuel Gas code ANSI Z223.1/NFPA 54*, the *Natural Gas and Propane Installation code CSA B149-1*, or the *Propane Storage and Handling Code CSA B149.2*.

All Electrical Components must be electrically grounded in accordance with local codes or in the absence of local codes with the *National Electrical Code NFPA 70* or *Canadian Electrical code Part 1 (CSA C22.1)*.

CALIFORNIA PROPOSITION 65 - WARNING Pursuant to California Health & Safety Code Sec. 25249.6

Appliances that use Natural Gas and Propane emit toxic combustion byproducts, that are on the list of substances which are known by the State of California to cause cancer and / or birth defects or other reproductive harm. To minimize exposure to these substances, always operate this unit in a well ventilated area and according to this use and care manual.

For additional information, please go to <https://www.p65warnings.ca.gov>.

FOR OUTDOOR INSTALLATION AND USE ONLY:

This outdoor cooking gas appliance must only be used outdoors and must not be used in a building, garage, or any other enclosed area.

ILLUSTRATIONS AND DEFINITIONS OF OUTDOOR AREAS:

An appliance is considered to be outdoors if installed with shelter no more inclusive than with walls on three sides, but with no overhead cover (see image # 1) ; all openings must be permanently open; sliding doors, garage doors, windows, or screened openings are not considered as permanent openings or,

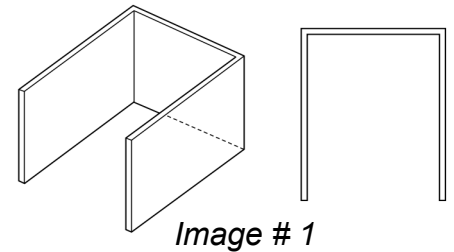

Image # 1

An appliance is considered to be outdoors if installed with shelter no more inclusive than within a partial enclosure that includes an overhead cover and no more than two sidewalls. The sidewalls may be parallel, as in a breezeway, or at right angles to each other (see image # 2 and # 3). All openings must be permanently open; sliding doors, garage doors, windows, or screened openings are not considered as permanent openings.

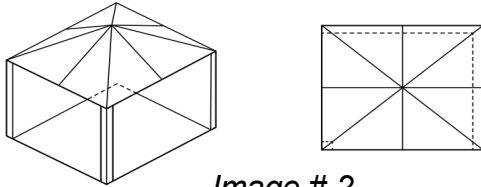

Image # 2

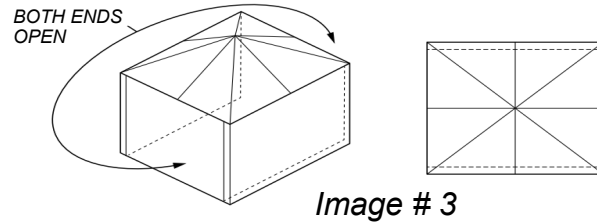

Image # 3

An appliance is considered to be outdoors if installed with shelter no more inclusive than within a partial enclosure that includes an overhead cover and three sidewalls, as long as 30% or more of the horizontal periphery of the enclosure is permanently open. (see image # 4 and # 5), All openings must be permanently open; sliding doors, garage doors, windows, or screened openings are not considered as permanent openings.

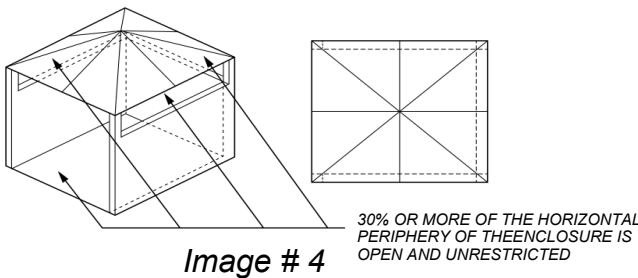

Image # 4

30% OR MORE OF THE HORIZONTAL PERIPHERY OF THE ENCLOSURE IS OPEN AND UNRESTRICTED

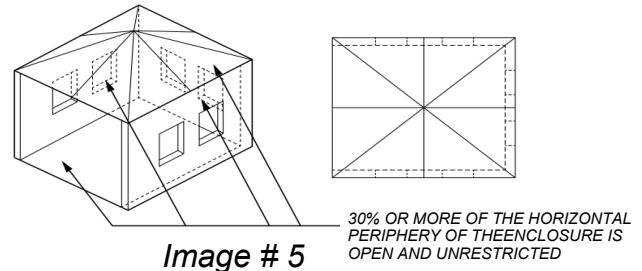

Image # 5

30% OR MORE OF THE HORIZONTAL PERIPHERY OF THE ENCLOSURE IS OPEN AND UNRESTRICTED

APPLIANCE SERIAL NUMBER LABEL:



NOTICE

THIS OUTDOOR COOKING APPLIANCE IS NOT INTENDED TO BE INSTALLED IN OR ON BOATS. THIS APPLIANCE IS NOT INTENDED TO BE INSTALLED IN OR ON RECREATIONAL VEHICLES.

CLEARANCES:

It is necessary to maintaining proper clearances from combustible construction, the specific minimum clearances from such construction to the sides and back of this cooking gas appliance is shown in the serial label.

SERIAL NUMBER LABEL IN THIS AREA

INFORMATION FOUND IN THE SERIAL PLATE:

- MODEL AND SERIAL NUMBER
- POWER / FUEL TYPE & OPERATING PRESSURE
- BTUH AND ORIFICE SIZE OF EACH BURNER
- PRECAUTIONARY INFORMATION AS STATED BELOW:

FOR OUTDOOR USE ONLY. IF STORED INDOORS, DETACH AND LEAVE CYLINDERS OUTDOORS • (A) DO NOT STORE SPARE LP-GAS CYLINDER UNDER OR NEAR THIS APPLIANCE • (B) NEVER FILL THE CYLINDER BEYOND 80 % FULL IF THE INFORMATION IN (A) AND (B) IS NOT FOLLOWED EXACTLY, A FIRE CAUSING DEATH OR SERIOUS INJURY MAY OCCUR.

MINIMUM OPERATING TEMPERATURE: 0 °F (-17.8 °C)

MINIMUM CLEARANCE FROM SIDES AND BACK OF UNIT TO COMBUSTIBLE CONSTRUCTION: 3" FROM SIDES AND 3" FROM BACK.

CART MODEL: DO NOT USE THIS APPLIANCE UNDER OVERHEAD UNPROTECTED COMBUSTIBLE SURFACES.

BUILT IN UNIT: IF INSTALLED UNDER OVERHEAD COMBUSTIBLE CONSTRUCTION, THE APPLIANCE MUST BE INSTALLED IN CONJUNCTION WITH A SUITABLE AND APPROVED OUTDOOR VENT HOOD ONLY.

FOR BUILT-IN APPLIANCES: ONLY FOR INSTALLATION IN BUILT-IN ENCLOSURE CONSTRUCTED ENTIRELY OF NON-COMBUSTIBLE MATERIALS OR FOR INSTALLATION IN A BUILT-IN ENCLOSURE OF COMBUSTIBLE MATERIALS BUT WITH A COUNTERTOP AND ANYTHING ABOVE IT MADE OF NON-COMBUSTIBLE MATERIALS.

CONFORMS TO: ANSI Z21.58-2022 / CERTIFIED TO: CSA 1.6-2022
OUTDOOR COOKING GAS APPLIANCE

LOCATING AND ASSEMBLING THE SIDE BURNER:

When determining a suitable location for your Side Burner, take into account concerns such as exposure to wind, rain, sprinklers, proximity to traffic paths and keeping any gas supply line runs as short as possible. Locate the Side Burner only in a well-ventilated area. Never locate the Side Burner in a building, garage, breezeway, shed or other such enclosed areas without an approved ventilation system. Never locate the Side Burner under or next to unprotected combustible construction.

CLEARANCES:

TO NON-COMBUSTIBLE CONSTRUCTIONS:

A minimum of **3"** clearance around the Side Burner to non-combustible construction is required to allow heat to escape freely while cooking.

TO COMBUSTIBLE CONSTRUCTIONS:

The minimum clearance of the unit to combustible construction is indicated in the serial plate on page 3.

A minimum of **3"** clearance from the back and sides of the unit to non-combustible construction is required to allow the heat to escape if large diameter pots are used.

ASSEMBLY:

BUILT-IN MODELS: To locate your ALFRESCO™ Side Burner into your Non-combustible enclosure, complete the following steps:

1. Remove all packaging materials
2. Install and secure the body of the Side Burner to your counter's enclosure.
3. Ensure that the burners are positioned correctly on their venturi funnels, and are fully seated onto their supports. (See figure # 1 below)
4. Install the Side Burner Grate.
5. Make the connection to the gas regulator according to the instructions explained on pages 9 through 17 for your gas type.
6. To comply with safety and service requirements, main gas shut off valve must be accessible from front of Side burner without using any tools.

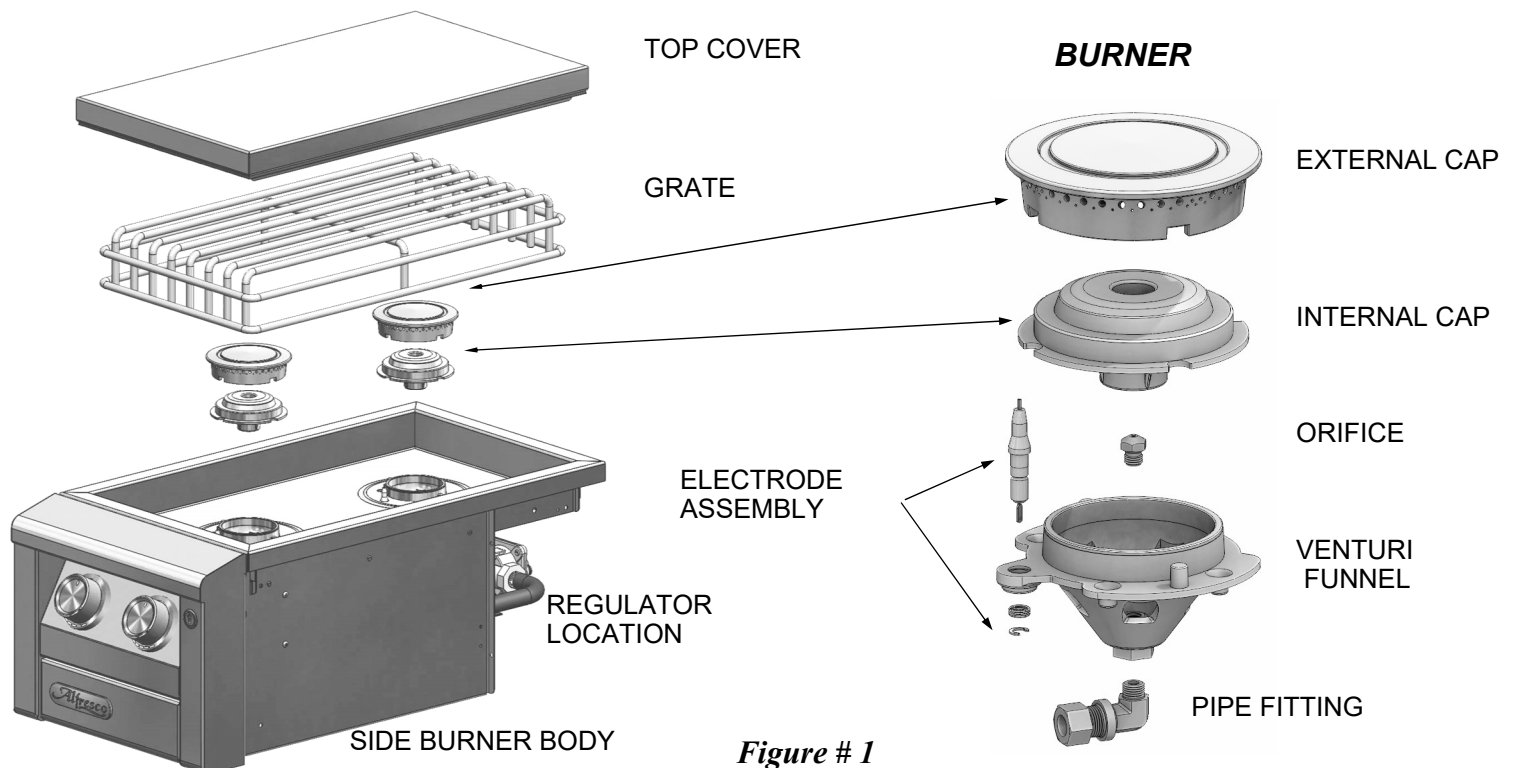

Figure # 1

CART MODELS:

Please follow the instructions supplied with the unit in order to mount and connect all required piping that comes with the unit.

WARNING:

To prevent harm and ensure proper operation of your Side Burner, it is imperative that the burners are properly installed with respect to the gas orifices. Be certain that the exterior cap and well as internal cap is inserted completely into the burner's venturi funnel and that the burner rests firmly on its supports.

The burner should not rock side-to-side nor top-to-bottom if properly installed. If excessive burner movement is present, reseal burner or contact your authorized service provider.

ELECTRICAL REQUIREMENTS:

The AIPGSB-2 Side Burner is equipped with a high output electrical ignition system and accent lights on the front panel of the unit.

The electrical system is designed to be operated at:

115VAC - 50 / 60 Hz.

The unit should be kept plugged into the receptacle (located under the counter and away from the elements) except when it is being disconnected for maintenance or troubleshooting (see page 24).

We recommend using a **GFCI Receptacle** to maintain proper grounding and safety at all times.

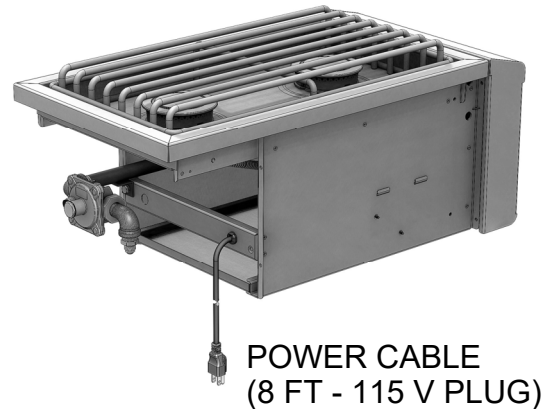

**POWER CABLE
(8 FT - 115 V PLUG)**

GAS CONNECTION—LIQUID PROPANE (LP)

NEVER CONNECT THE SIDE BURNER TO AN UNREGULATED GAS SUPPLY.

Before proceeding, ensure the unit is fitted for LP gas. Connecting to an improper gas type will result in poor performance and increased risk of damage or injury. Total gas consumption (per hour) with all burners set on "HI" is as follows:

- AIPGSB-2 40,000 BTUH

Manifold pressure with LP Operating: 10.0" W.C. Non-operating: 11.2" W.C.

LEAK TESTING:

GENERAL INFORMATION:

Although all gas connections on your Alfresco™ Side Burner are leak tested at the factory prior to shipment, a complete gas tightness check must be performed at the installation site due to possible mishandling in shipment, or excessive pressure unknowingly being applied to the unit.

Periodically check the whole system for leaks, or immediately check if the smell of gas is detected.

In order to check for leaks, it is necessary to connect and pressurize the side burner with the fuel supply system of your choice such as a local liquid propane (LP) tank system or a fixed piped system of natural gas (NG) or a remote LP system.

Follow the fuel connection instructions in this manual prior to conducting any leak testing.

GAS CONNECTIONS INFORMATION:

For LP or NG fuel systems with flexible hoses, please inspect the hose before each use of the outdoor cooking gas appliance. If it is evident that there is excessive abrasion or wear, or the hose is cut, it shall be replaced prior to the outdoor cooking gas appliance being put into operation.

If the unit is installed with a flexible rubber hose / regulator assembly, only replace with assembly part number:

- **PROP-KIT-01**

This assembly consists of a 36" long hose with a 3/8" ODF fitting and dual in-line regulator with a **QCC1** connection.

Contact Alfresco™ for replacement.

If the unit is installed with a flexible metal (stainless) hose or a coated stainless hose, (minimum 1/2" ID for NG and 3/8" ID for LP), similar hoses are available for replacement at plumbing stores, supply warehouses or home centers.

All rigid pipes, semi-flexible tubing and connectors must comply with **ANSI Z21.75** and **CSA 6.27** as suitable for outdoor installation.

The maximum length of the connection must be 6 Ft (1.82 m).

CONNECTION ACCESS:

FOR BUILT IN UNITS: Locate the access plate or door provided in the outdoor counter or island for inspection of gas lines / shut-off valves and electrical connections.

FOR CART MOUNTED UNITS: For LP cart mounted units, inspection of the flexible hose, regulator and tank can be done by opening the doors of the cart. For NG cart mounted units, the flexible hose is available for inspection on the back of the cart unit.

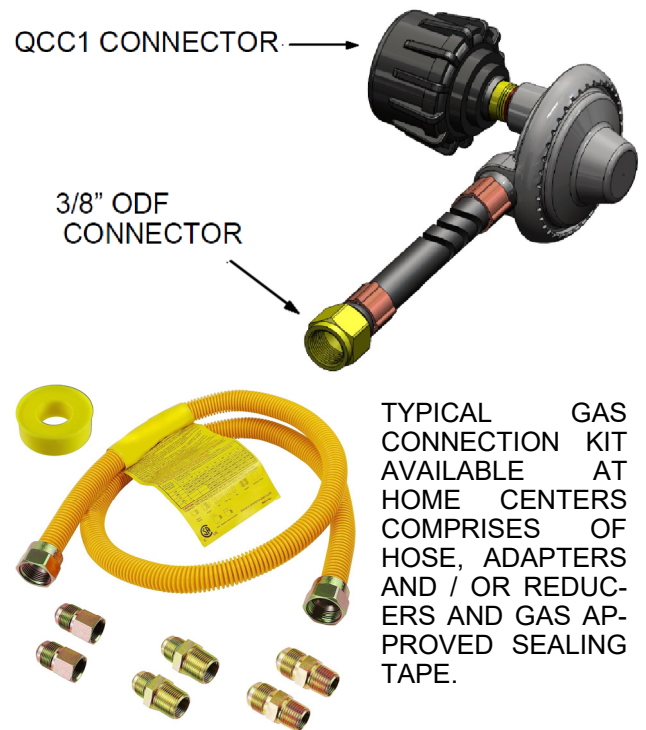

⚠️ WARNING

ELECTRICAL GROUNDING INSTRUCTIONS:

THIS OUTDOOR COOKING GAS APPLIANCE IS EQUIPPED WITH A THREE-PRONG (GROUNDING) PLUG FOR YOUR PROTECTION AGAINST SHOCK HAZARD AND SHOULD BE PLUGGED DIRECTLY INTO A PROPERLY GROUNDED THREE-PRONG RECEPTACLE. DO NOT CUT OR REMOVE THE GROUNDING PRONG FROM THIS PLUG.

⚠️ AVERTISSEMENT

INSTRUCTIONS DE MISE À LA TERRE ÉLECTRIQUE

CET APPAREIL DE CUISSON AU GAZ D'EXTÉRIEUR EST ÉQUIPÉ D'UNE FICHE À TROIS BROCHES (MISE À LA TERRE) POUR VOTRE PROTECTION CONTRE LES RISQUES D'ÉLECTROCUTION ET DEVRAIT ÊTRE BRANCHÉ DIRECTEMENT DANS UNE PRISE À TROIS BROCHES CORRECTEMENT MISE À LA TERRE. NE PAS COUPER OU ENLEVER LA PRISE MISE À LA

⚠️ WARNING

KEEP ANY ELECTRICAL CORD AND FUEL SUPPLY HOSE AWAY FROM ANY HEATED SURFACES.

⚠️ AVERTISSEMENT

GARDER TOUT LE CORDON ÉLECTRIQUE ET LE TUYAU D'ALIMENTATION DE CARBURANT À L'ÉGARD DE TOUTES SURFACES CHAUFFANTES.

⚠️ WARNING

THE COVER MUST BE REMOVED WHEN LIGHTING.

THE COVER SHOULD NOT BE CLOSED WHEN THE BURNERS ARE IN USE.

⚠️ AVERTISSEMENT

LE COUVERCLE DOIT ÊTRE ENLEVÉ LORS DE L'ÉCLAIRAGE.

LE COUVERCLE NE DOIT PAS ÊTRE FERMÉ LORS DE L'UTILISATION DES BRÛLEURS.

BUTTON SYMBOLS, CONTROLS SWITCHES AND LOCATIONS:

There is one button located on the upper right corner of the front panel of the Side burner. The button is meant to turn ON and OFF the front panel accent lights

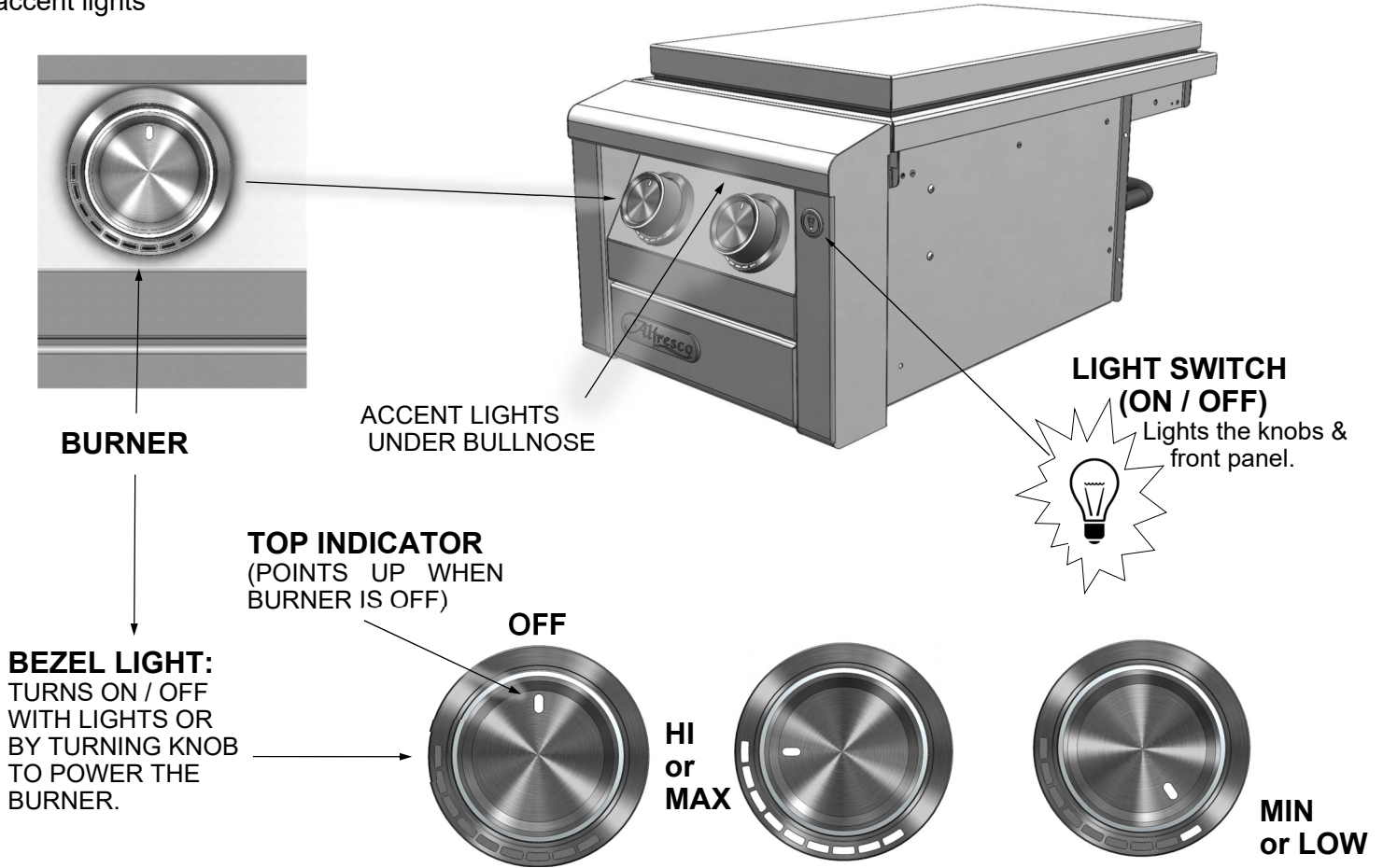

BURNER POWER:

INDICATES THE RELATIVE POWER OF THE BURNER WHEN THE BURNER IS TURNED ON.
(Refer to page 8 for additional information)

ADDITIONAL CONTROLS:

There are 2 additional buttons located under the front panel to control the different lighting options (color and brightness) of your Control Panel and Knobs. Push the switch to cycle through your options.



LIGHT LEVEL SWITCH:
8 light levels (brightness) to choose from.

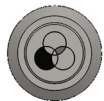

LIGHT COLOR SWITCH:
20 colors you can choose from.



NOTE:
OPEN DRIP TRAY
TO ACCESS
LIGHT SWITCHES

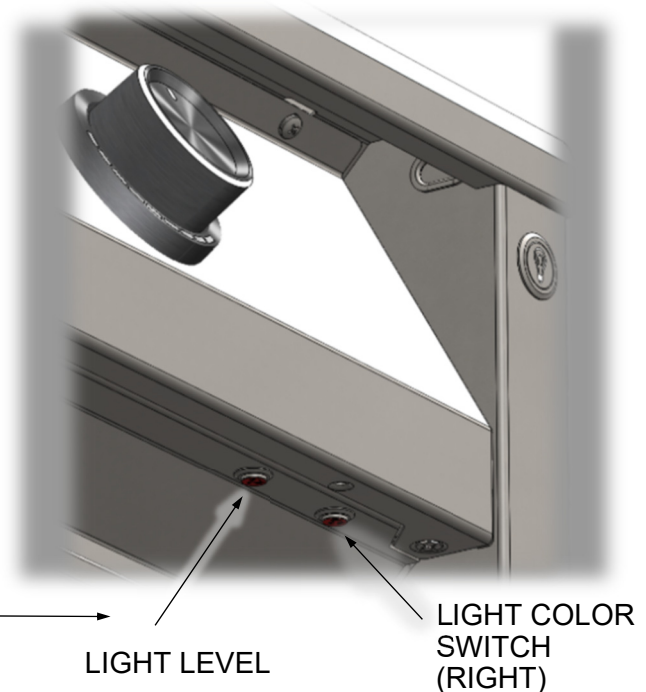

LIGHTING INSTRUCTIONS:

BEFORE LIGHTING...

The pressure regulator and hose assembly supplied with the unit must be used. Never substitute regulators for those supplied with the Side Burner. If a replacement is necessary, contact the factory for proper replacement.

Screw the regulator (**Type QCC1**) into the LP tank. Leak check the hose and regulator connections with a soap and water solution before operating as explained on the LEAK TESTING section of this manual.

SIDE BURNER LIGHTING:

Turn all knobs to “OFF” and then turn on the gas supply. Adjustable valves are labeled **OFF MAX ► MIN**.

KEEP YOUR FACE AND BODY AS FAR AWAY FROM THE SIDE BURNER AS POSSIBLE WHEN LIGHTING !

LIGHTING THE BURNERS:

- To light the burners simply push and rotate the proper knob counterclockwise 90° to the “HI” position and wait for the burner to light.
- The system has an auto-ignition feature that sparks when there is no flame and re-ignites if necessary for sparking again. Sparking stops when the flame is present.
- The knobs control the amount of heat the burner produces.
- **HI** (90° counterclockwise with 9 LEDs) produces the most amount of heat.
- **LOW** (by continuing to turn to 1 LED) produces the least amount of heat.

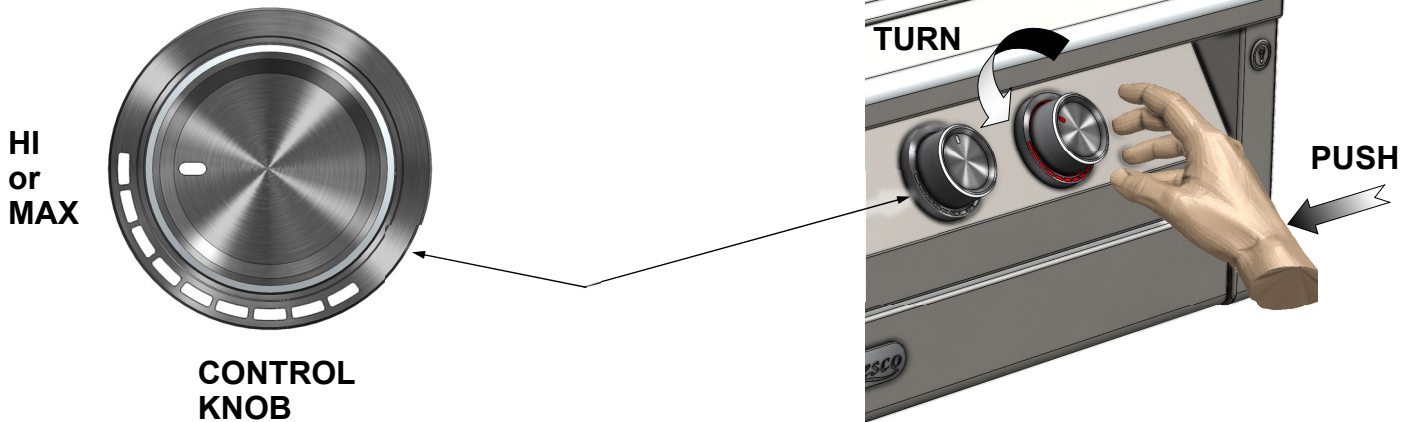

NOTE: The first burner may take longer to light while air is purged from the gas supply system.

If the burner does not light in 4 seconds, turn knobs to “OFF” and wait 5 minutes to allow any accumulated gas to dissipate before trying again. If the burner will not light after several attempts, then it can be lit with a match.

FRONT BURNER: Push and turn the side burner right hand control knob 90° counter-clockwise to the **MAX** position and immediately depress the right hand igniter button. You'll hear a snapping sound from the spark which will be provided to both side burners. It is necessary to keep the igniter button depressed until the burner is lit.

REAR BURNER: Repeat the same operation as explained on the front burner but using the side burner left hand control knob. If either burner does not light within 4 seconds, turn knob to “OFF” and wait 5 minutes to allow any accumulated gas to dissipate before trying again.

If the burner will not light after several attempts see page 24: Troubleshooting.

GENERAL MAINTENANCE INSTRUCTIONS:

1. Keep the outdoor cooking gas appliance area clear and free from combustible materials, gasoline, and other flammable vapors and liquids;
2. DO NOT obstruct the flow of combustion and ventilation air;
3. Keep the ventilation opening (s) of the cylinder enclosure (if any) free and clear from debris;
4. Visually check burner flames.

CAUTION

IN SUNNY ENVIRONMENTS, THE FLAME FROM AN IR BURNER MAY BE IMPOSSIBLE TO SEE.

MISE EN GARDE

DANS LES ENVIRONNEMENTS SOLEILS, LA FLAMME D'UN BRÛLEUR IR PEUT ÊTRE IMPOSSIBLE À VOIR.

PARTS AND REPLACEMENTS:

For information regarding obtaining replacement parts please refer to “How to obtain service” on page 26 of this manual.

OPERATING TEMPERATURE:

The minimum operating temperature for safe use of this outdoor cooking gas appliance is 0 °F (-17.8 °C)

NOTE:

PORTABLE (CART-MOUNTED) OUTDOOR SIDE BURNERS MUST NOT BE USED UNDER OVERHEAD COMBUSTIBLE CONSTRUCTION.

SELF CONTAINED LIQUID PROPANE (LP) GAS SUPPLY SYSTEMS:

L.P. TANK REQUIREMENTS:

Use only a standard 20 Lb. (5 Gallons) propane gas cylinder (18-1/4” H x 12-1/4” Ø). The tank must be installed in the upright position. Do not use a dented or rusty LP tank as it may be hazardous and should be checked by your LP supplier. Never use a cylinder with a damaged valve.

The LP cylinder shall be constructed and marked in accordance with the Specification *for LP Gas Cylinders of the U.S. Department of Transportation (DOT)* or **CSA B339**.

The cylinder must be provided with a shut off valve terminating in an LP gas supply cylinder valve outlet specified, as applicable, for connection type **QCC1** according to the standard for compressed gas cylinder valve outlet and inlet connections **CGA 791**.

LP GAS CONNECTION TO LP TANKS:

Your ALFRESCO™ Side Burner for use with LP gas comes equipped with its own regulator, which **MUST NOT** be removed. There is also a secondary high capacity, hose/regulator assembly for connection to a standard 20 Lb. LP cylinder. The LP gas pressure regulator and hose supplied with this unit must be used without alteration.

If this assembly needs to be replaced use only the type specified by ALFRESCO™ for this appliance.

To connect the regulator / hose assembly follow the next steps:

- Locate the regulator and gas connection point in the rear side of your Side Burner unit .
- Verify that the a 1/2" FPT x 1/2" MPT (male-to-female) 90° Elbow connected to the regulator points in the required direction. (see **Figure # 2**)
- Fasten the hose connection to a 1/2" MPT x 3/8" COMP (compression flare fitting) connected to the elbow. (see **Figure # 2**).

• **PROP-KIT-01**

This assembly consists of a 36" long hose with a 3/8" ODF fitting and dual in-line regulator with a **QCC1** connection.

To connect the LP Regulator / Hose Assembly follow the diagram on the next page:

LP TANK CONNECTION STEPS:

1. Locate the regulator and gas connection point in the rear right side of your BBQ unit (in cart mounted models, remove the rear panel from the BBQ cart to gain access).
2. Attach a 1/2" FPT x 1/2" MPT (male-to-female) elbow to the regulator.
3. Attach a 1/2" MPT x 3/8" ODF (compression flare fitting) reducer to the elbow in order to connect to the LP tank regulator / hose assembly.

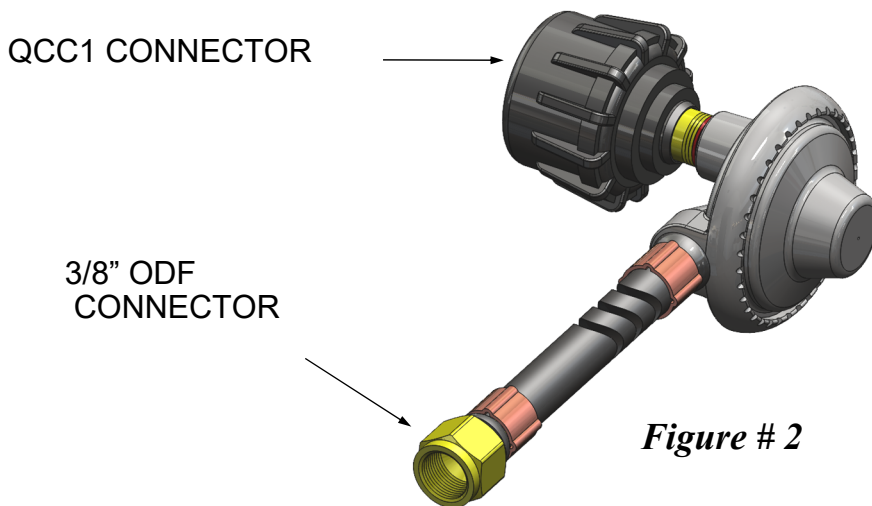

LP GAS CONNECTION TO LP PIPED SYSTEMS:

An LP piped system is one with a large central LP tank that feeds the entire household. Those systems are normally equipped with a high pressure regulator by the large LP tank and low pressure regulators close to the home.

CONVERTIBLE GAS
PRESSURE REGULATOR

1/2" FPT X 1/2"
MPT
90° ELBOW

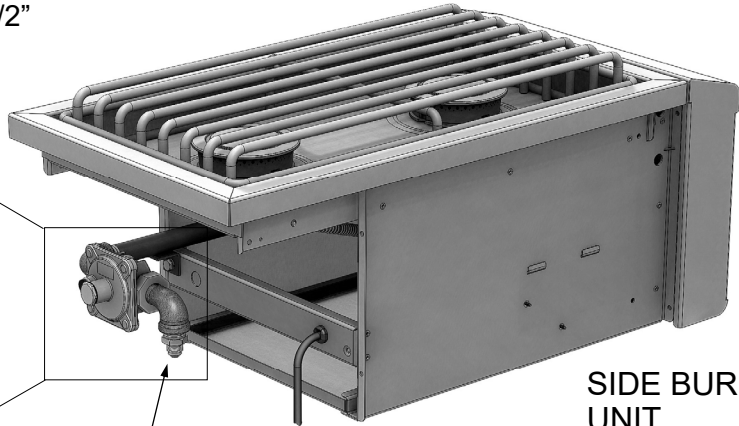
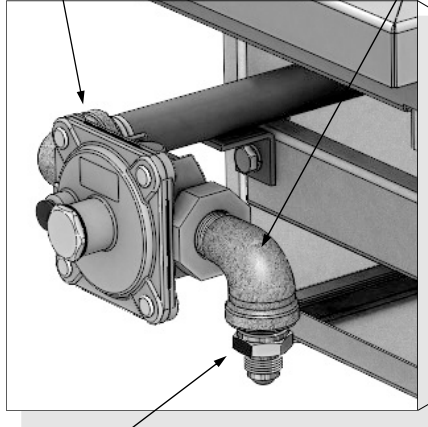

SIDE BURNER
UNIT

POWER CABLE (8FT LONG)

1/2" FPT X 3/8"
FLARE BRASS

TYPICAL 20 LBS.
(5 GALLONS)
LP GAS TANK

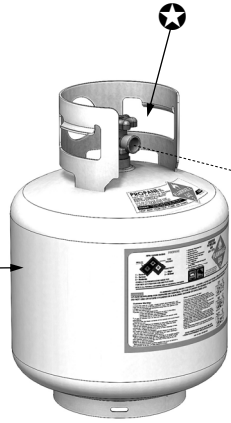

LP REGULATOR
AND HOSE
ASSEMBLY
(PRESET TO 10")

⚠ WARNING

KEEP ANY ELECTRICAL CORD AND FUEL SUPPLY HOSE AWAY FROM ANY HEATED SURFACES.

⚠ AVERTISSEMENT

GARDER TOUT LE CORDON ÉLECTRIQUE ET LE TUYAU D'ALIMENTATION DE CARBURANT À L'ÉGARD DE TOUTES SURFACES.

GAS CONNECTION - NATURAL GAS (NG)

NEVER CONNECT THE SIDE BURNER TO AN UNREGULATED GAS SUPPLY.

Before proceeding, ensure the unit is fitted for natural gas (regulator settings as well as orifices). Connecting to an improper gas type will result in poor performance and increased risk of damage or injury. Installation of this cooking appliance must be made in accordance with local codes. In the absence of local codes, this unit should be installed in accordance with the *National Fuel Gas Code No. Z223.1/NFPA 54*, *Natural Gas and Propane Installation code CSA B149-1*, or *Propane Storage and Handling Code B149.2*.

Manifold pressure with NG:	Operating:	4.0" W.C. (.14 PSI)
	Non-operating:	4.5" W.C. (.16 PSI)
	Optimum pressure:	7.0" W.C. (.25 PSI)

NOTE: To ensure proper heating performance of this appliance, verify that the gas line supply pressure is adequate (7.0" W.C. supply pressure is preferred) to maintain 4.5" W.C. manifold pressure. Use a minimum 1/2" ID flex hose to prevent gas starvation.

NATURAL GAS CONNECTION:

Ensure that the service pipe supplying the Side Burner is fitted with a shut off valve conveniently positioned and easily accessible as an emergency gas shutoff.

Your ALFRESCO™ Side Burner for use with Natural Gas comes equipped with its own regulator which **MUST NOT** be removed.

The hose as well as the connectors must comply with the *Standard for Connectors for Outdoor Gas Appliances and Manufactured Homes, ANSI Z21.75* and **CAS 6.27**.

If this regulator needs to be replaced use only the type specified by ALFRESCO™ for this appliance. To connect the piping or hose assembly follow the next steps:

- Locate the regulator and gas connection point in the rear side of your Side Burner.
- Verify that the a 1/2" FPT x 1/2" MPT (male-to-female) 90° Elbow connected to the regulator points in the required direction. (see **Figure # 3**)
- Fasten the pipe or hose connection to a 1/2" MFT elbow with the appropriate gas fittings. (Flex hose or hard pipelines) (see **Figure # 4**).

If the connection of the Side Burner is done with flare fittings and a flexible hose to the existing NG gas supply, a 1/2" diameter flexible stainless steel gas hose, no more than 48" in length will be required.

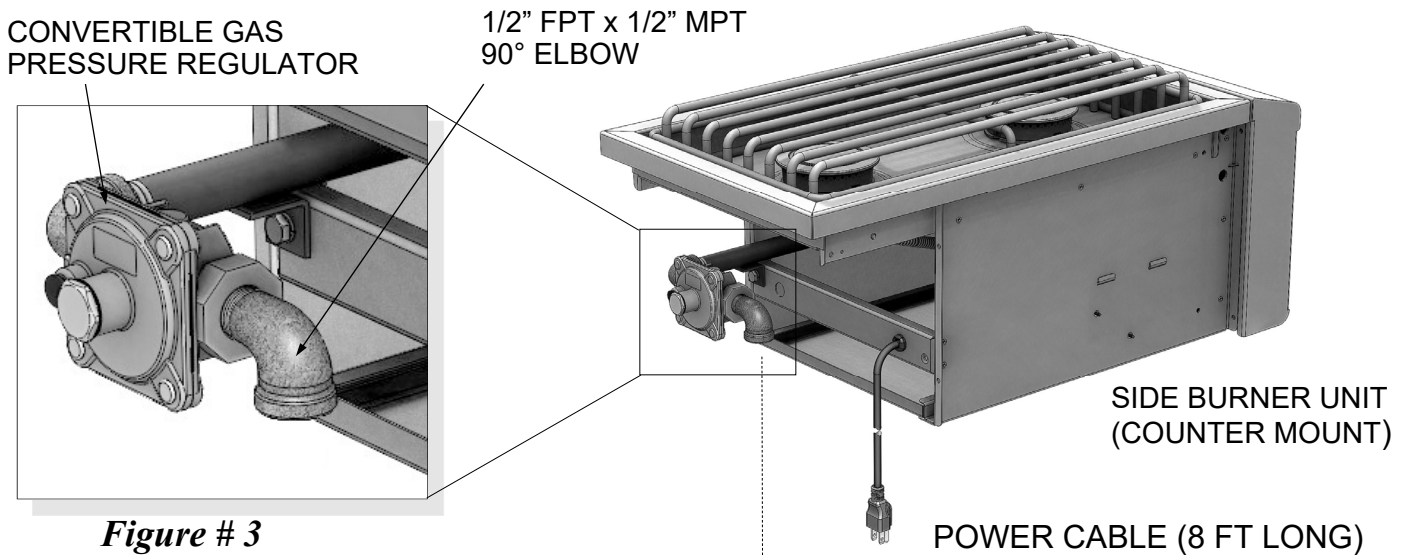

Figure # 3

NG FLEXIBLE HOSE OR RIGID PIPE

INCOMING NG GAS SUPPLY

SHUT OFF HAND VALVE MUST BE LOCATED IN ACCESSIBLE AREA

Figure # 4

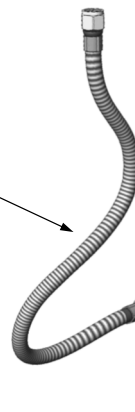

LEAK TESTING LP TANK CONNECTIONS:

BEFORE TESTING:

- Make sure all the side burner control knobs are in the **OFF** position.
- Do not smoke while leak testing.
- Never leak test with an open flame.
- Make a soap solution of one part liquid detergent and one part water for leak testing purposes.
- Always check with a full cylinder.

TO TEST:

- Apply the solution to the gas fittings marked with a star (★) on the previous page by using a spray bottle, or a brush to spread the solution.
- Turn the gas supply (LP Tank valve) to the **OPEN** position..
- Check all connections from the LP cylinder up to and including the manifold pipe assembly.
- Soap bubbles will appear is a leak is present.
- If a leak is present, immediately turn **CLOSE** the LP Tank valve, tighten any leaking fittings, turn the gas supply back **ON** and RECHECK again.
- If you cannot stop a gas leak **CLOSE** the LP Tank valve and call your dealer where you purchased your side burner.
- Do not use the side burner until all connections have been checked and do not leak.

ALWAYS CHECK FOR LEAKS AFTER EVERY LP TANK CHANGE.

IMPORTANT INFORMATION:

Check all gas supply fittings for leaks before each use. It is handy to keep a spray bottle of soapy water near the shut-off valve of the gas supply line. Spray all the fittings. Bubbles indicate leaks.

If the outdoor cooking gas appliance is not in use, the gas shall be turned off at the supply cylinder. An outdoor cooking gas appliance may be stored indoors only if the cylinder is disconnected and removed from the outdoor cooking gas appliance.

Cylinders shall be stored outdoors out of the reach of children and shall not be stored in a building, garage, or any other enclosed area.

The LP gas cylinder used shall include a collar to protect the cylinder valve.

- Do not store a spare LP gas cylinder under or near this appliance.
- Never fill the cylinder beyond 80% full.
- If the information above is not followed exactly, a fire causing death or serious injury could occur.

This outdoor cooking gas appliance is designed to use a **CGA 791** connection. Place a dust cap on the LP cylinder valve outlet whenever the cylinder is not in use. Only install the type of dust cap on the cylinder valve outlet that is provided with the cylinder valve. Other types of caps or plugs may result in leakage of propane.

The LP gas cylinder face elastomeric face seal element (O-Ring) on these devices could, over time, show marked and visible damage or deterioration that might cause a leak even with the connection tightened.

A visual inspection for the seal must be carried out every time a LP gas cylinder is replaced or refilled; any LP gas cylinder showing signs of damage or deterioration as those illustrated below, including visible cracks and pitting, must be returned unused to the LP gas cylinder seller.

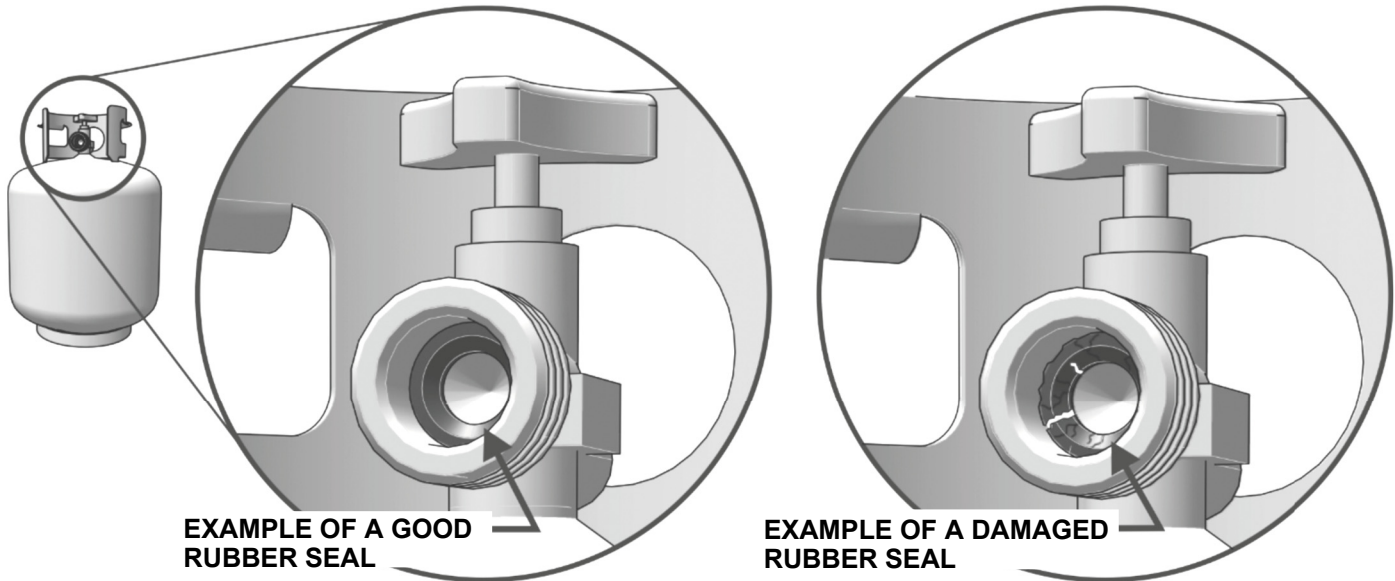

CART-MOUNTED LP GAS CONNECTION TO AN LP FIXED FUEL SYSTEMS:

An LP Fixed Fuel System is one with a large central LP tank that feeds the entire household. Those systems are normally equipped with a high pressure regulator by the large LP tank and low pressure regulators close to the home.

For this type of installation:

- **DO NOT** use the LP small tank regulator supplied with the unit (such as the one shown on page 10 with a **QCC1** type connection).
- Connect the gas line for this type of installation directly to the unit's convertible gas pressure regulator (see page 10) through the back panel of the cart assembly in similar fashion as a typical NG gas connection (see page 11) using a flexible hose connected to a required gas shut-off valve.
- **NOTE:** The convertible gas pressure regulator must be set for LP gas. (The factory pre-sets the regulator in LP units).

All rigid pipes, semi-flexible tubing and connectors must comply with the *Standard for Connectors for Outdoor Gas Appliances and Manufactured Homes*, **ANSI Z21.75** and **CAS 6.27**, and suitable for outside installation. The maximum length of the connection must be 6 Ft. (1.82 m)

INFORMATION FOR LP FIXED FUEL SYSTEMS TESTING:

- The outdoor cooking gas appliance and its individual shut-off valve must be **disconnected** from the gas supply piping system during any pressure testing of that system at test pressures in excess of 1/2 psi (3.5 kPa)
- The outdoor cooking gas appliance must be **isolated** from the gas supply piping system by closing its individual manual shut-off valve during any pressure testing of the gas supply piping system at test pressures equal to or less than 1/2 psi (3.5 kPa).

BUILT-IN OUTDOOR COOKING GAS APPLIANCE MODELS:

- ***THIS OUTDOOR COOKING GAS APPLIANCE MUST NOT BE USED UNDER OVERHEAD UNPROTECTED COMBUSTIBLE CONSTRUCTION.***
- ***IF INSTALLED UNDER OVERHEAD COMBUSTIBLE CONSTRUCTION, THE APPLIANCE MUST BE INSTALLED IN CONJUNCTION WITH A SUITABLE OUTDOOR APPROVED VENT HOOD ONLY. THE VENT HOOD MUST BE PLACED IN OPERATION DURING OPERATION OF THE APPLIANCE.***

The built-in enclosure should be properly constructed with a typical average industry height of 36", a width of no less than 6" wider than the appliance overall width and a minimum depth as specified in the specification sheet of this outdoor cooking gas appliance.

Please consult local building codes and requirements. Specification sheets are available with your retailer, or contact Alfresco™ Grills or go to www.alfrescogrills.com

The built-in enclosure should be built of the appropriate non-combustible materials such as granite, stone brick, cement, etc. and metal framing components whenever possible.

The outdoor cooking appliance should never be operated while on top of combustible countertops such as, Formica®, Corian®, Azure®, Quartz Composite materials including wood, laminates, wood composites nor countertops with combustible materials, binders or components including finishes such as oils, lacquer, varnish, shellac, paints or other combustible finishes.

This appliance is only for installation in a built-in enclosure of non-combustible materials.

OVERHEAD CONSTRUCTION PROTECTION AND EXHAUST REMOVAL:

IMPORTANT: Never install the Side Burner under overhead unprotected combustible construction.

If install under any type of combustible construction, the use of an approved outdoor exhaust hood **is required**. The exhaust hood provides the required protection for overhead unprotected combustible construction.

ADDITIONALLY, THE REQUIRED EXHAUST HOOD SHOULD BE:

- Approved Outdoor hood.
- Installed according to the manufacturer's instructions.
- Have it's own GFCI protected branch circuit power supply.
- Have a minimum airflow of **1200 CFM's** for baffled filtered hoods or **900 CFM's** for non-baffled filtered hoods.
- Installed at a least 30" over the cooking surface.
- Hood intake area should be at least 3" ~ 6" bigger (side to side and front to back) than the side burner's cooking surface area.

NOTE:

Heavy and fast rising smoke is a challenging situation for any exhaust hood or vent system.

Constant wind or wind drafts will also affect the ability of the exhaust hood to catch smoke during operation.

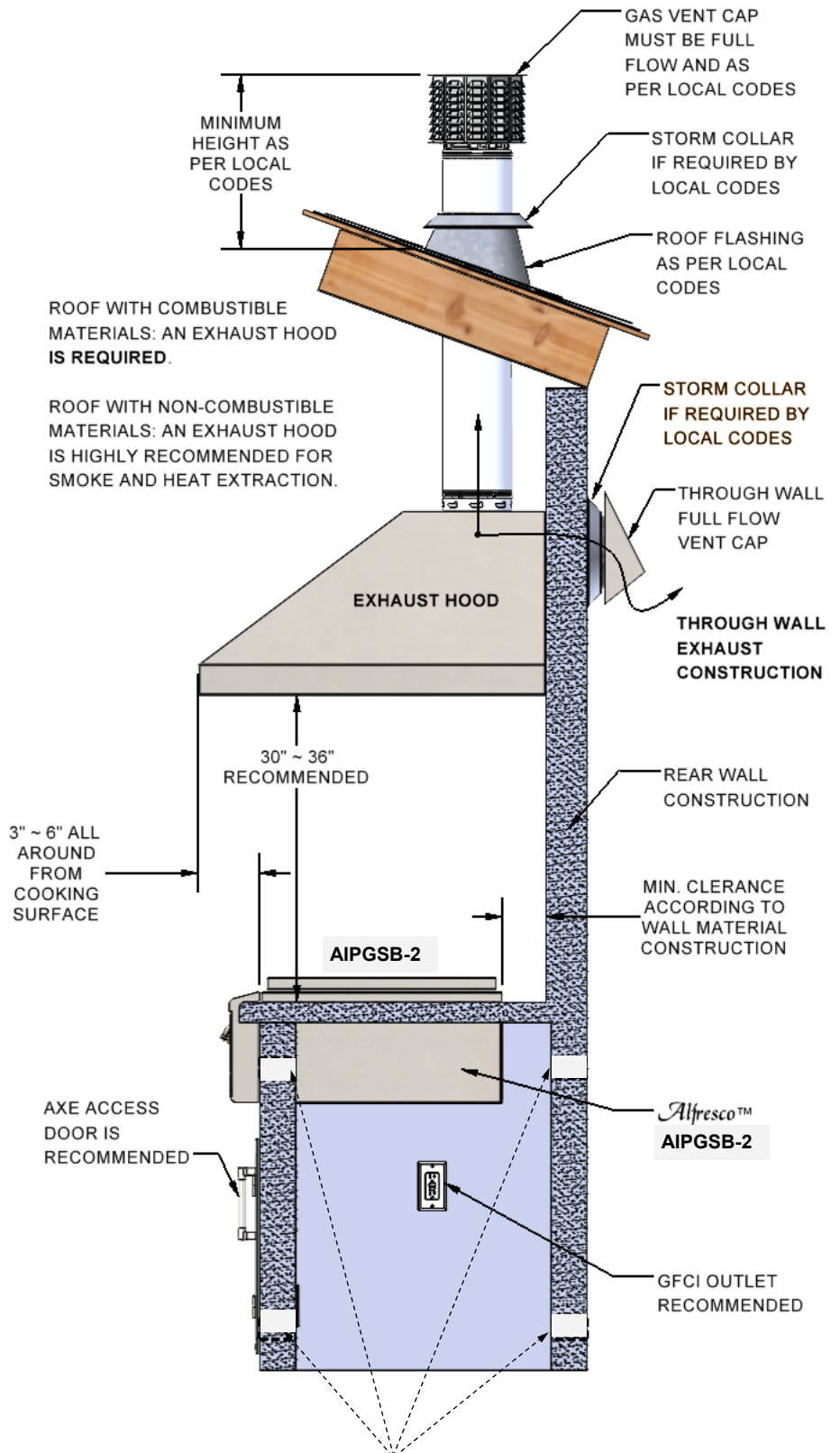

TOP AND BOTTOM VENTILATION AS PER ANSI Z21.58 CLAUSE 4.6

VENTILATION ACCORDING TO LP ENCLOSURES SHOWN ON PAGE (17) ALSO REQUIRED FOR NG SYTEMS.

BUILT-IN APPLIANCES GAS CONNECTION - LP CYLINDER ENCLOSURES

When the outdoor cooking gas appliance is installed in a built in enclosure that requires the use of LP by means of a gas cylinder, the use of the gas appliance tank drawer AXE-18LPTDR-SC is highly recommended. Refer to the AXE-18LPTDR-SC specification sheet for installation.

The construction requirements for an LP-cylinder enclosure, should be such that the resultant construction complies with the requirements of **ANSI Z21.58 - 2022 Clause 4.6**

CAUTION THE ABOVE CODE IS THE MINIMUM. MORE VENTILATION IS RECOMMENDED AS IS ALWAYS SAFER.

BUILT-IN CONNECTION PASS THROUGH SEALED AS PER REQUIREMENTS ABOVE.

**TOP AND BOTTOM VENTILATION AS PER ANSI Z21.58 CLAUSE 4.6
AT LEAST ONE VENT (UNOBSTRUCTED) TO EXTERIOR OF ENCLOSURE
TOP: MINIMUM 1 in²/lb (14.2 cm²/ kg) FUEL CAPACITY
BOTTOM: MINIMUM 1/2 in²/lb (7.1 cm²/ kg) FUEL CAPACITY**

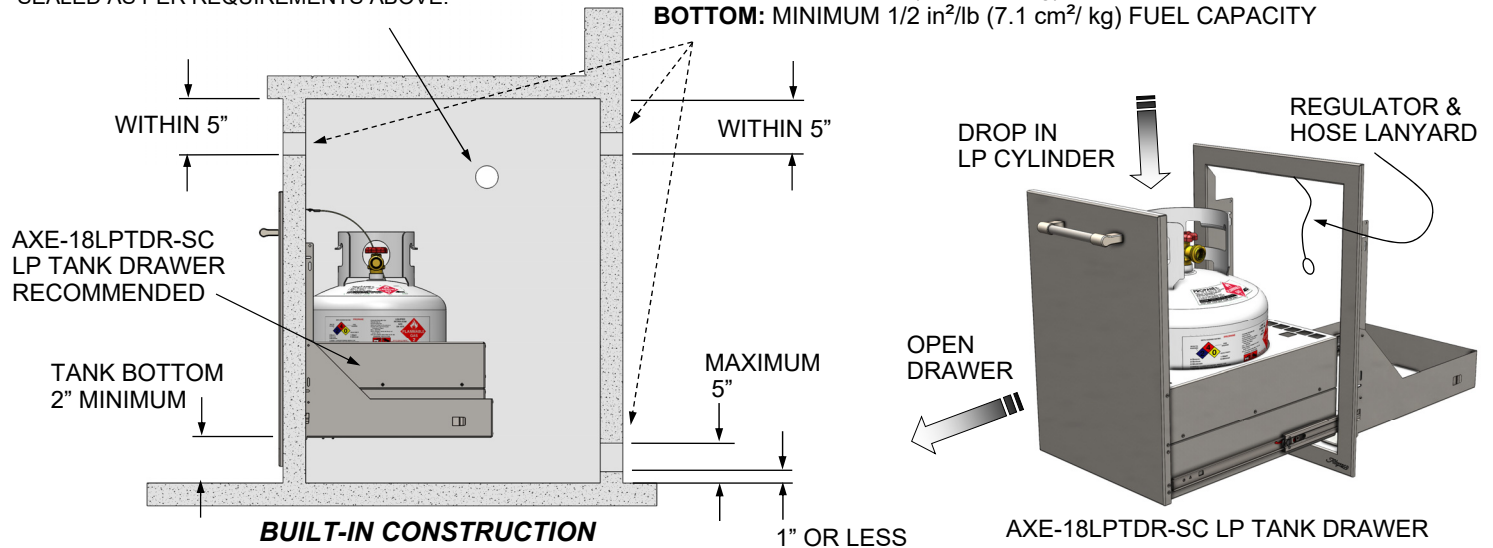

TANK RETENTION POINTS:

When the AXE-18LPTDR-SC cylinder gas drawer is installed in the built-in construction, the typical standard 20 Lbs. (5 Gallons) LP cylinder rests on the center of the tank tray and it is retained in place (preventing the tank from tipping sideways) by the design of the drawer itself. The cylinder can rotate freely but can't fall out of the drawer tray or tip over.

LP REGULATOR HOSE ASSEMBLY RETENTION:

In addition to retaining the LP tank, it is also required to properly support the LP Regulator / Hose Assembly and prevent the unit from falling to the ground during LP tank exchanges as per ANSI Z21.58 regulations. For this purpose, when installing the included LP Regulator and Hose Assembly, fasten the assembly to the AXE-18LPTDR-SC frame with the included Regulator & Hose lanyard.

ENCLOSURES FOR BUILT-IN APPLIANCE WITH REMOTE LP GAS SUPPLY SYSTEM

An enclosure for built in units with remote LP gas supply systems shall be ventilated by openings at both the upper and lower levels of the enclosure. Ventilation shall be accomplished by one of the following:

- One side of the enclosure, other than the front, shall be completely open, or
- For an enclosure having four sides, a top, and a bottom:
 - At least one ventilation opening shall be provided on the exposed exterior side of the enclosure located within 5 in (127mm) of the top of the enclosure and unobstructed. The opening's shall have a total free area of not less than 3 in² per 1000 Btu/h (293 W) of the largest single burner capacity.
 - At least one ventilation opening shall be provided on the exposed, exterior side of the enclosure 1 in (25.4 mm) or less from the floor level and shall have a total free area of not less than 3 in² per 1000 Btu/h (293 W) of the largest single burner capacity. The upper edge shall be no more than 5 in (127 mm) above the floor level.

- Every opening shall have a minimum dimension so as to permit the entrance of a 3/16 in (4.8 mm) rod.
- Ventilation openings shall not communicate directly with other compartments of the enclosure and,
- Ventilation openings shall not be located in front of the appliance above floor level.

BUILT-IN APPLIANCE LP GAS CONNECTION TO A REMOTE LP GAS SUPPLY SYSTEMS:

A remote LP Fuel System is one with a large central LP tank that feeds the entire household. Those systems are normally equipped with a high pressure regulator by the large LP tank and low pressure regulators close to the home.

For this type of installation:

- **DO NOT** use the LP small tank regulator supplied with the unit (such as the one shown on page 10 with a **QCC1** type connection).
- Connect the gas line for this type of installation directly to the unit's convertible gas pressure regulator in similar fashion as a typical NG gas connection (*See page 17*) using a flexible hose connected to a required gas shut-off valve.
- **NOTE:** The convertible gas pressure regulator must be set for LP gas. (The factory pre-sets the regulator in LP units).
- The connectors used shall be the those provided with this appliance or those specified on page 6 of this manual. Such rigid pipes, semi-flexible tubing and connectors must comply with the *Standard for Connectors for Outdoor Gas Appliances and Manufactured Homes, ANSI Z21.75* and **CAS 6.27**, and suitable for outside installation. The maximum length of the connection must be 6 Ft. (1.82 m)
- The connector and primary shut-off valve should be accessible through door opening in the built-in enclosure.
- All the rigid pipes, flexible tubing or gas connectors should be as short as possible in order to be self supporting, otherwise they must be supported by mechanical means (ie: enclosure framing plus additional pipe support straps or clamps) in order to minimize vibration.
- All the rigid pipes, flexible tubing or gas connectors must be protected as they pass through openings in the compartment of the built-in enclosure according to ANSI Z21.58 2022 Clause 4.6

For all other types of rigid pipe, semi-rigid tubing, and/or connectors available to connect an appliance to a fixed fuel piping system that can be obtained at plumbing stores, supply warehouses or home centers, the connection must be made with by the use of a rigid pipe, semi-rigid tubing, and/or connectors that comply with **ANSI Z21.75** and **CSA 6.27** standards.

BUILT-IN APPLIANCE INFORMATION FOR LP FIXED FUEL SYSTEMS TESTING:

When the Outdoor Cooking Gas Appliance is meant to be used with other than self contained LP gas supply systems the following information should be taken into consideration during testing:

- The outdoor cooking gas appliance and its individual shut-off valve must be **disconnected** from the gas supply piping system during any pressure testing of that system at test pressures in excess of 1/2 psi (3.5 kPa)
- The outdoor cooking gas appliance must be **isolated** from the gas supply piping system by closing its individual manual shut-off valve during any pressure testing of the gas supply piping system at test pressures equal to or less than 1/2 psi (3.5 kPa).

ELECTRICAL CONNECTIONS - LINE VOLTAGE

This Outdoor Cooking Gas Appliance has been tested in accordance with: **ANSI Z21.58-2022** and **CSA 1.6-2022**, *The Standard for Outdoor Cooking Gas Appliances*.

Please follow this instructions for your safety:

- a) To protect against electric shock, do not immerse cord or plugs in water or other liquid.
- b) Unplug from the outlet when not in use and before cleaning. Allow to cool before putting on or taking off parts.
- c) Do not operate any outdoor cooking gas appliance with a damaged cord or plug, or after the appliance malfunctions or has been damaged in any manner. Contact Alfresco™ Gourmet Grills for repair.
- d) Do not let the cord hang over the edge of a table or touch hot surfaces.
- e) Do not use an outdoor cooking gas appliance for purposes other than intended.
- f) When connecting, first connect plug to the outdoor cooking gas appliance then plug appliance into the outlet.
- g) Use only a Ground Fault Interrupter (GFI) protected circuit with this outdoor cooking gas appliance.
- h) Never remove the grounding plug or use with an adapter of two prongs.
- i) Use only extension cords with a three-prong grounding plug, rated for the power of the equipment, and approved for outdoor use with a W-A marking

WARNINGS:

- If the information in this manual is not followed exactly, a fire or explosion may result causing property damage, personal injury or death.
- Do not try lighting this appliance without reading the **LIGHTING INSTRUCTIONS** section of this manual. For outdoor use only.
- This cooking appliance is not intended to be installed in or on recreational vehicles and / or boats.

BEFORE USING THE SIDE BURNER:

- Ensure that the side burner has been leak tested. (see page 5 and 13)
- Remove any packing material.
- Read and understand the instructions in this manual.
- Electric power supply must be plugged-in at all times for barbecue operation; except during any electrical maintenance.

NOTES CONCERNING GFCI USE AND LOCATION:

1. Do not attempt to circumvent using a GFCI receptacle, it is for your safety.
2. Ensure that the GFCI receptacle is located in an easily accessed location.
3. Follow the manufacturer's instructions for installation and testing (must comply with local and national codes).

WARNING

ELECTRICAL PARTS AND COMPONENTS
DISCONNECT ALL POWER SUPPLIES AND
BATTERIES BEFORE SERVICING.

AVERTISSEMENT

PIÈCES ÉLECTRIQUES ET COMPOSANTS.
DÉBRANCHER TOUS LES BLOCS D'ALIMENTATION
ET LES PILES AVANT DE LES RÉPARER.

WARNING

FLAMMABLE GAS
DISCONNECT ALL PROPANE OR NATURAL
GAS SUPPLIES TO THIS UNIT BEFORE SERVICING.

AVERTISSEMENT

GAZ INFLAMMABLE
DÉBRANCHER TOUS LES GAZ PROPANE OU GAZ
NATUREL DE CET APPAREIL AVANT DE
PROCÉDER À L'ENTRETIEN.

WARNING

NEVER USE A DENTED OR RUSTED LIQUID PROPANE TANK. SHUT OFF TANK WHEN NOT IN USE.

AVERTISSEMENT

N'UTILISEZ JAMAIS DE RÉSERVOIR DE PROPANE LIQUIDE BOSSELÉ OU ROUIL-LÉ. ÉTEINDRE LE RÉSERVOIR LORSQU'IL N'EST PAS UTILISÉ.

WARNING

DO NOT ATTEMPT TO LIGHT THE SIDE BURNER IF THE ODOR OF GAS IS PRE-SENT. CALL FOR SERVICE.

AVERTISSEMENT

N'ESSAYEZ PAS D'ALLUMER LE BRÛ-LEUR LATÉRAL SI UNE ODEUR DE GAZ EST PRÉSENTE. APPEL DE SERVICE.

WARNING

FOR OUTDOOR USE ONLY
NOT TO BE INSTALLED IN OR ON RECREATIONAL VEHICLES AND / OR BOATS.

AVERTISSEMENT

POUR UTILISATION À L'EXTÉRIEUR
NE PAS ÊTRE INSTALLÉ DANS OU SUR DES VÉHICULES RÉCRÉATIFS ET / OU DES BATEAUX.

CAUTION

CYLINDERS MUST BE STORED OUTDOORS IN A WELL VENTILATED AREA OUT OF THE REACH OF CHILDREN.

DISCONNECTED LP CYLINDERS MUST HAVE THREAD-ED VALVE PLUGS TIGHTLY INSTALLED, AND MUST NOT BE STORED IN A BUILDING, GARAGE OR ANY OTHER ENCLOSED AREA. THE GAS MUST BE TURNED OFF AT THE SUPPLY CYLINDER WHEN THE UNIT IS NOT IN USE. IF THE APPLIANCE IS STORED INDOORS, THE CYLINDER MUST BE DISCONNECTED AND RE-MOVED FROM THE APPLIANCE.

WARNING

YOUR ALFRESCO™ SIDE BURNER PRES-SURE REGULATOR HAS A **MAXIMUM INPUT PRESSURE OF 14" WC.** (OR APPROX. .5 PSI) , AND A **SAFETY LIMIT OF 69" WC.** (2.5 PSI).

MISE EN GARDE

LE CYLINDRE DOIT ÊTRE STOCKÉ À L'EXTÉRIEUR DANS UN ENDROIT BIEN VENTILÉ ET HORS DE LA PORTÉE DES ENFANTS.

DÉBRANCHER LES BOUTEILLES DE LP DOIVENT AVOIR DES BOUCHONS DE VALEUR VISSÉS HERMÉ-TIQUEMENT INSTALLÉS, ET NE DOIVENT PAS ÊTRE STOCKÉS DANS UN BÂTIMENT, GARAGE OU TOUT AU-TRE ESPACE FERMÉ. LE GAZ DOIT ÊTRE ARRÊTÉ AU NIVEAU DU CYLINDRE D'ALIMENTATION LORSQUE L'APPAREIL N'EST PAS UTILISÉ. SI L'APPAREIL EST ENTREPOSÉ À L'INTÉRIEUR, LE CYLINDRE DOIT ÊTRE DÉBRANCHÉ ET RETIRÉ DE L'APPAREIL.

AVERTISSEMENT

LE RÉGULATEUR DE PRESSION DE VOTRE BRÛLER LATÉRAL ALFRESCO A UNE PRES-SION D'ENTRÉE MAXIMALE DE 14" WC (OU EN-VIRON 0,5 PSI), ET UNE LIMITE DE SÉCURITÉ DE 69" WC (2,5 PSI).

REGULATOR NOTICE

EXPOSURE TO PRESSURES ABOVE THE SAFETY LIMIT OF 69" WC. WILL PERMANENTLY DAMAGE THE GAS REGULATOR REQUIRING A REPLACEMENT.

OVER PRESSURE DAMAGE IS NOT COVERED BY YOUR ALFRESCO WARRANTY

SAFETY PRACTICES TO AVOID PERSONAL INJURY

READ THIS CARE AND USE MANUAL CAREFULLY AND COMPLETELY BEFORE USING YOUR SIDE BURNER TO REDUCE THE RISK OF FIRE, BURN HAZARD OR OTHER INJURY. KEEP THIS MANUAL FOR FUTURE REFERENCE.

When properly cared for, your ALFRESCO™ Side Burner will give safe, reliable service for many years. However, extreme care must be used since the Side Burner produces intense heat, which can increase accident potential. When using this appliance, basic safety practices must be followed, including but not limited to the following:

- Begin by ensuring proper assembly. A qualified technician should perform all other service.
- Do not repair or replace any part of the Side Burner unless specifically recommended in this manual.
- All other service should be referred to and performed by a qualified technician.
- For personal safety, wear proper apparel. Loose fitting garments or sleeves should never be worn while using this appliance. Some synthetic fabrics are highly flammable and should not be worn while cooking.
- Never let clothing, pot holders or other flammable materials come in contact with or too close to any grate, burner or hot surface until it has cooled down sufficiently. Fabrics may ignite and result in personal injury.
- Use only dry potholders: moist or damp potholders on hot surfaces may cause personal burns from steam. Do not use a towel or bulky cloth in place of potholders. Do not let potholders touch hot portions of the Side Burner grate.
- Only certain types of glass, heatproof glass ceramic, earthenware, or other glazed utensils are suitable for Burner use. These types of materials may break with sudden temperature changes. Use only on low or medium heat settings and according to their manufacturer's directions.
- Grease is flammable. Let hot grease cool before attempting to handle it.
- Avoid letting grease deposits collect in the bottom of the Side Burner by cleaning the grease tray often. Never while the Side Burner is on or hot from recent use; pan will not come out.
- Do not use aluminum foil to line the Side Burner grates, nor to line the drip tray. This can severely upset combustion airflow or trap excessive heat in the control area. The result of this can be melted knobs, igniters and increased chance of personal injury.
- Never cook without the drip pan in place and pushed all the way to the back of the Side Burner. Without the drip pan, hot grease can leak downward creating a fire or explosion hazard.
- Children should not be left alone or unattended in an area where the Side Burner is being used. Never allow them to sit, stand or play on or around the Side Burner. Do not store items of interest to children around or below the Side Burner or in the cart. Never allow children to crawl inside of the cart.
- Do not heat unopened food containers that may cause the container to build-up pressure and burst.
- Never lean over an open hot or operating Side Burner.
- When lighting a burner, always pay close attention to what you are doing. Be certain you are depressing the correct igniter button labeled for the burner you intend on using.
- When using the Side Burner do not touch the Side Burner grate or immediate surrounding area as these areas become extremely hot and could cause burns.

- For proper lighting and performance of the burners keep the ports clean. It is necessary to clean them periodically for optimum performance. The burners will only operate in one position and must be mounted correctly for safe operation.
- Clean the Side Burner with caution. Avoid steam burns; do not use a wet sponge or cloth to clean the Side Burner while it is hot. Some cleaners produce noxious fumes or can ignite when applied to a hot surface.
- **INSECT WARNING:** Spiders and insects can nest in the burners of this Side Burner and cause the gas to flow from the wrong side of the burner. This is a very dangerous condition, which can cause a fire to occur behind the valve panel, thereby damaging the Side Burner and making it unsafe to operate. Inspect the Side Burner at least twice a year.
- Be sure all Side Burner controls are turned off and the Side Burner is cool before using any type of aerosol cleaner on or around the Side Burner. The chemical that produces the spraying action could, in the presence of heat, ignite or cause metal parts to corrode.
- Do not operate the Side Burner under unprotected combustible construction. Use only in well ventilated areas. Do not use in buildings, garages, sheds, breezeways or any enclosed areas.
- Keep the area surrounding the Side Burner free from combustible materials, trash, or combustible fluids and vapors such as gasoline or charcoal lighter fluid. Do not obstruct the flow of combustion gases and ventilation airways.
- Keep the back of the cart free and clear from debris (cart model).
- If the unit is stored indoors ensure that it is cool. If propane is used, the cylinder must be unhooked and the propane cylinder stored outside in a well-ventilated area, out of reach of children.
- Never use the Side Burner in windy conditions. If located in a consistently windy area, oceanfront, mountaintop, etc... a windbreak will be required. Always adhere to the specified clearances.
- Keep any electrical supply cord, away from the heated areas of the Side Burner.

⚠ WARNING

FOR OUTDOOR USE ONLY
NOT TO BE INSTALLED IN OR ON
RECREATIONAL VEHICLES AND / OR
BOATS.

⚠ WARNING

**NEVER USE A DENTED OR RUSTED LIQUID
PROPANE TANK. SHUT OFF TANK WHEN
NOT IN USE.**

⚠ AVERTISSEMENT

POUR UTILISATION À L'EXTÉRIEUR
NE PAS ÊTRE INSTALLÉ DANS OU SUR
DES VÉHICULES RÉCRÉATIFS ET / OU DES
BATEAUX.

⚠ AVERTISSEMENT

**N'UTILISEZ JAMAIS DE RÉSERVOIR DE PRO-
PANE LIQUIDE BOSSELÉ OU ROUILLÉ.**
**ÉTEINDRE LE RESERVOIR LORSQU'IL N'EST
PAS UTILISÉ.**

BURNER ADJUSTMENTS

LOW HEAT SETTING ADJUSTMENT:

NOTE:

THE LOW HEAT SETTING ON YOUR SIDE BURNER IS PRESET AT THE FACTORY. ADJUST ONLY IF ALTITUDE OR ENVIRONMENTAL FACTORS ARE CAUSING POOR, LOW HEAT, PERFORMANCE.

ADJUSTMENT STEPS:

1. Follow lighting instructions by setting the control knob on "HI" (see page # 7) and allow the burner to preheat for 5 minutes.
1. Turn the control knob to "LOW" and wait for the burner temperature to drop and stabilize.
2. *Attempting adjustment at any setting other than LOW can create a dangerous condition.*
3. Remove knob by pulling straight away from control panel.
4. Insert a small blade screwdriver into the valve stem to begin the adjustment.
5. Turn counter-clockwise to INCREASE the low heat flame using pliers to hold the stem securely. (see figure # 5)
6. Adjust the flames so the burner is fully lit around the perimeter when the knob is in the LOW position. Once proper adjustment is reached, reattach the knob by pushing

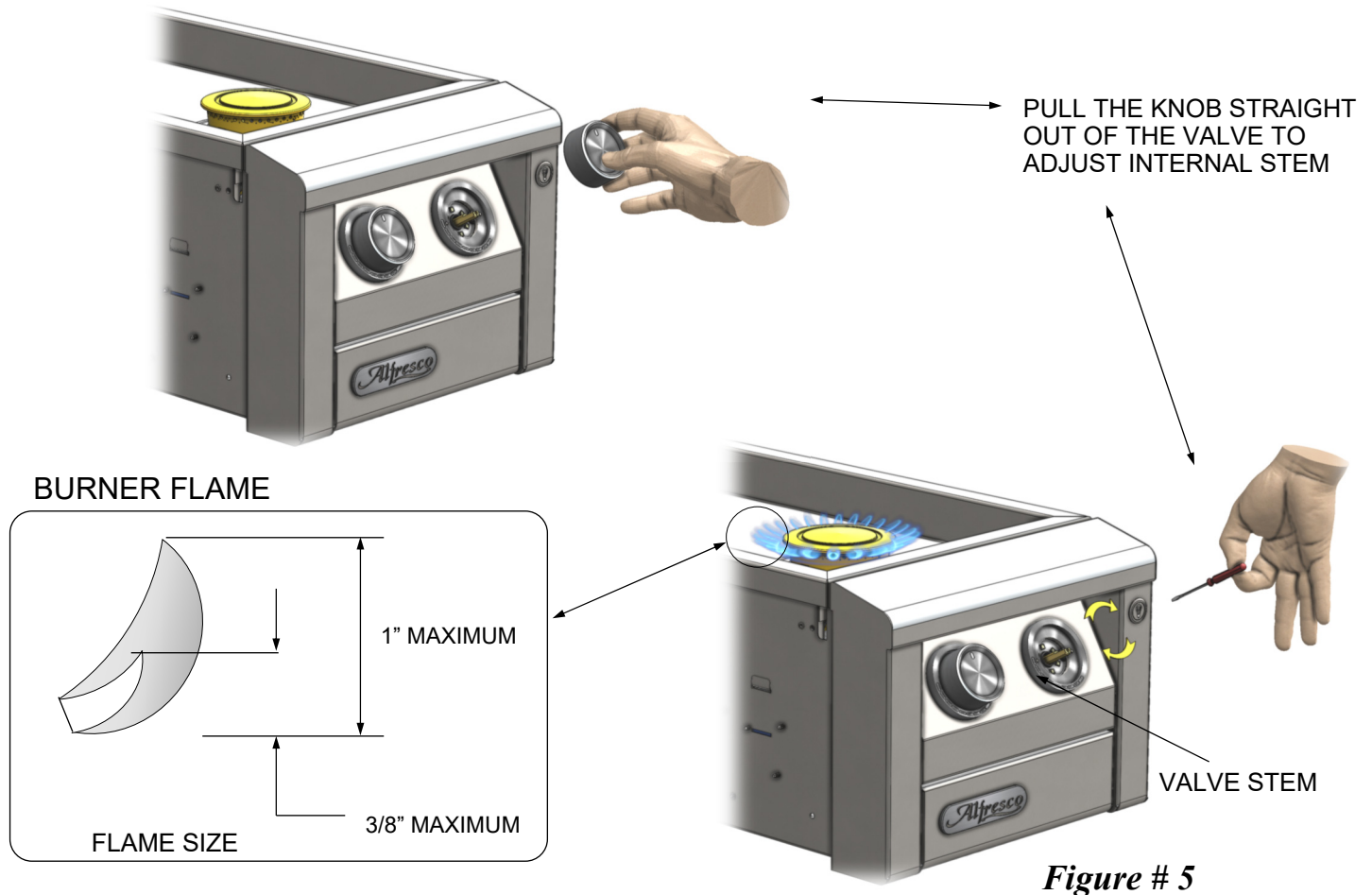

⚠ WARNING

NEVER ADJUST THE BURNER SO LOW THAT IT MAY GO OUT DURING USE. DO NOT OPERATE THE BURNER WITH THE LOW HEAT SCREW REMOVED.

GAS CAN ESCAPE AND CAUSE A POTENTIALLY HAZARDOUS CONDITION.

⚠ AVERTISSEMENT

NE JAMAIS RÉGLER LE BRÛLEUR À FAIBLE NIVEAU QU'IL PEUT S'ÉTEINDRE PENDANT SON UTILISATION. NE PAS UTILISER LE BRÛLEUR AVEC LA VIS À FAIBLE CHALEUR ENLEVÉE.

LE GAZ PEUT S'ÉCHAPPER ET PROVOQUER UNE CONDITION POTENTIELLEMENT DANGEREUSE.

STAINLESS STEEL CARE:

Stainless Steel is widely used for catering and residential kitchen equipment because of its strength, its ability to resist corrosion and its ease of cleaning. In fact, stainless steel ranks alongside glass and new china in terms of “ease of cleaning” and in percentage removal of bacteria during washing. As a result of these virtues, the metal is often taken for granted and it is assumed that no problems will arise during its usage. However, some care is required to ensure that the stainless steel can live up to this reputation.

DAY TO DAY CARE:

To maintain the original appearance of your ALFRESCO™ Side Burner, a regular cleaning routine should be carried out using the following guidelines:

1. After use, following the safety precautions detailed on page 21 and 22, wipe the Side Burner with a soft damp soapy cloth and rinse with clean water, preferably warm/hot water. This should remove most substances encountered during the cooking process.
2. For more tenacious deposits, including oil, grease and water-borne deposits, use a multi purpose cream cleanser and apply with a soft damp cloth. Rinsing with fresh water, as described above, should follow as a last step. For really stubborn dirt or burnt-on grease, a nylon-scouring pad may be used in conjunction with the cream cleanser. On no account should “wire wool” pads be used unless they are made of stainless steel.
3. Harsh abrasives and scouring materials should not be used for cleaning stainless steel as they will leave scratch marks in the surface and damage the appearance of the Side Burner. Likewise do not use wire brushes, scrapers or contaminated scouring pads.
4. Your ALFRESCO™ Side Burner has a directional polished grain, any cleaning with abrasives should be carried out along this grain direction and not across it.
5. After use, always remove wet cleaning aids (such as cloths, pads, containers) from the surface, to avoid formation of water marks or stains.
6. If required, dry the Side Burner after use with a soft dry cloth or towel.

If the preceding guidelines are adhered to, your ALFRESCO™ Side Burner should offer excellent life and should live up to its reputation of being “stainless”. Neglect of this practice, however, can lead to deterioration of the surface and, in some extreme cases, corrosion of the steel itself. The two most common types of corrosion that may be encountered, particularly on stainless steel, are rust marks and pitting of the surface.

RUST-BROWN MARKS:

When this type of staining occurs it is unlikely that rusting of the stainless steel itself caused the marks. Similar marks can be found with both porcelain and plastic sinks. The rust marks are more likely to be the result of small particles of “ordinary-steel” which have become attached to the surface; these have subsequently rusted in the damp environment. The most common source of such particles is from “wire-wool” scouring pads, but contamination may also occur from carbon steel utensils and old cast iron water supply pipes.

These brown marks are only superficial stains, which will not harm the Side Burner; they should be removable using a soft damp cloth and a multi-purpose cream cleanser. Occasionally, it may be necessary to resort to a proprietary stainless steel cleanser, to return the surface of the Side Burner to its original condition. To avoid re-occurrence of any “rust-staining” it is essential that the source of the contamination is eliminated.

PITTING:

Another form of corrosion, which occasionally occurs in stainless steel, is pitting of the surface. The reason for this corrosive attack can usually be attributed to certain household products, for example:

Bleaches:

Most common domestic bleaches & sterilizing solutions contain chlorine in the form of sodium hypochlorite. If used in concentrated form, bleaches can attack the stainless steel, causing pitting of the surface. They should always be used to the strengths prescribed by the manufacturer and should be thoroughly rinsed off with clean water immediately after use. All cleaning agents containing hypochlorite are unsuitable for long term contact with stainless steel and, even when used in the highly diluted form, they can produce pitting under certain conditions.

Foodstuffs:

In general stainless steel is fully resistant to all foodstuffs in common use. Only in isolated cases, such as when concentrated salt and vinegar mixtures are allowed to remain in contact with the steel for a long period, can any surface marking result.

ADDITIONAL IMPORTANT CLEANING AND STORAGE CONSIDERATIONS:

In order to maintain your Side Burner in clean working order, it will be necessary, under certain conditions, to take additional precautions. If your Side Burner is located in a coastal area, it will be exposed to salty air which is corrosive.

If it is located close to a swimming pool or Jacuzzi with chlorinated water, then it will be exposed to dilute hydrochloric acid which can be formed as a result of chlorine compounds used in the pool causing chlorine to be combined with hydrogen and water in the atmosphere.

Also, muriatic acid (another name for hydrochloric acid) is used to maintain the correct ph balance in the pool water. Chlorine is an oxidizing agent, and as such can promote rapid corrosion or other oxidizing processes which can damage various materials.

Type 304 stainless steel is highly resistant to corrosion but given enough exposure to such corrosive conditions might succumb to some degree, such that pitting or rusting may occur. Our Side Burner materials have been tested in saline solutions with higher salinity than sea water, and they have been tested in highly chlorinated solutions.

They have also been tested by exposure to highly acidic foods. During and after these tests, we found these materials were able to withstand exposure over prolonged periods of time.

However, the above mentioned corrosive substances, along with neglect, can lead to a situation whereby conditions might combine to cause some damage to occur. Therefore, we suggest that you always keep your Side Burner clean, dry and covered when not in use. This is even more important when long term storage is intended; always store the Side Burner clean, dry and covered with your cover.

Also, do not allow any food particles or grease to be left inside your Side Burner, as this will attract rodents which, in addition to being undesirable from an hygienic standpoint, are likely to cause physical damage to your Side Burner. Rodents are known to chew on the insulation of wiring which will eventually cause permanent damage to the wiring and possibly electrical components.

One final consideration for Side Burners located either along the coast or in a desert community: Wind driven sand is highly abrasive, therefore constant exposure will eventually pit and scratch almost anything; one more reason to keep your Side Burner covered when not in use. By routinely caring for your Side Burner as outlined in this manual, you can enjoy many years of service from it and keep it looking the way it should.

In the event that any light rusting is found on the stainless steel, it will usually not be the stainless steel which is corroding but iron particles which have somehow been deposited on the surface. For more information on this subject, please request our "Rust removal bulletin". As a first course of action though, we recommend "Bar Keepers Friend", available from many supermarkets and hardware stores.

This product, if used as directed, will usually solve the problem. Note though, when using this product on textured surfaces such as your barbecue, always rub in the direction of the grain; never across the grain, since doing so will damage the finish.

TROUBLESHOOTING: BEFORE CALLING FOR SERVICE:

If your ALFRESCO™ Side Burner does not function properly use the following checklist before contacting your dealer for service. You may save the cost of a service call and the inconvenience of being without your Side Burner. Additional troubleshooting tips can be found on our website at: www.alfrescogrills.com.

SPIDER AND INSECT WARNING: Spiders and insects can nest in the burners of this or any other Side Burner, and cause the gas to flow from the wrong side of the burner. This is a very dangerous condition, which can cause a fire to occur behind the valve panel, thereby damaging the Side Burner and making it unsafe to operate.

WHEN TO LOOK FOR SPIDERS: You should inspect the burners at least twice a year or immediately if any of the following conditions occur:

1. The smell of gas in conjunction with the burner flames appearing yellow.
2. The Side Burner does not reach temperature.
3. The Side Burner heats unevenly.
4. The burners make popping noises.

SIDE BURNER WON'T LIGHT:

First determine if the spark igniters are functioning properly. A rapid snapping sound should be heard when the igniter button is depressed. If no sound is heard, check the power. If the spark igniters are working correctly, next determine if gas is reaching the burners. Ensure the gas supply is turned on, and that there are no leaks according to the procedure on page 10 - 13. Attempt to match-light a burner according to the procedure on page 8.

If the burner will light with a match, then the spark igniter may not be functioning correctly. If the burner will not match light, and the gas supply has been confirmed, then check the burner for blockages.

FLAME IS YELLOW / GAS SMELL:

IF YOU SMELL GAS WHILE THE SIDE BURNER IS OPERATING, IMMEDIATELY TURN OFF ALL BURNERS. Perform a leak test and check for blockages.

NOTE: If the Side Burner is operating in a dusty area or if heavy grease is present on the burner cap, some orange tips on the burner flame should be considered normal.

BURNER BLOWS OUT:

First determine if the problem is being caused by location. Check the gas supply and flame characteristics. Check to ensure that burners are correctly positioned in their bodies according to the procedure on page 6 (assembly). Correctly installed burners should be seated firmly with no side-to-side movement.

LIGHTS DON'T WORK: Check that power is connected and that the GFCI has not tripped.

NOTE: Disconnect all power to your *Alfresco*™ Side burner unit before any light replacement is performed.

This unit, uses a NEON-LED light under the control panel bullnose. (see figure #6).

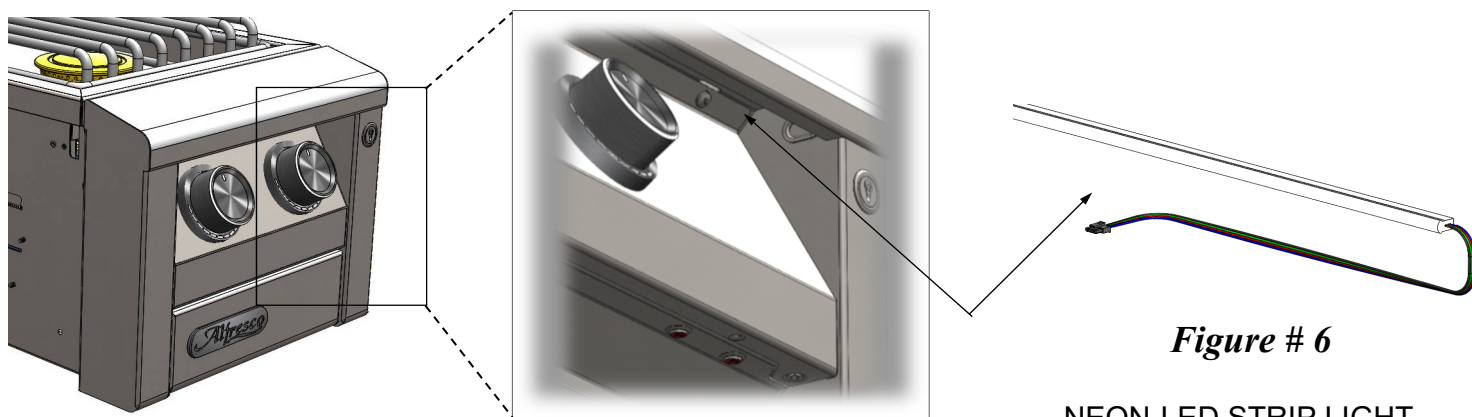

Figure # 6

NEON-LED STRIP LIGHT
(consult the factory for
part replacement)

HOW TO OBTAIN SERVICE

WARRANTY SERVICE ONLY:

VISIT US ON THE WEB AT: www.alfrescogrills.com

OR CALL US AT (866) 203-5607

Please provide:

- Model Number & Serial Number:
 - Side Burner - Located under the drip pan.
 - Refrigerators - Located inside on the upper left corner.
- Gas Type
- Date of installation
- A brief description of the problem.

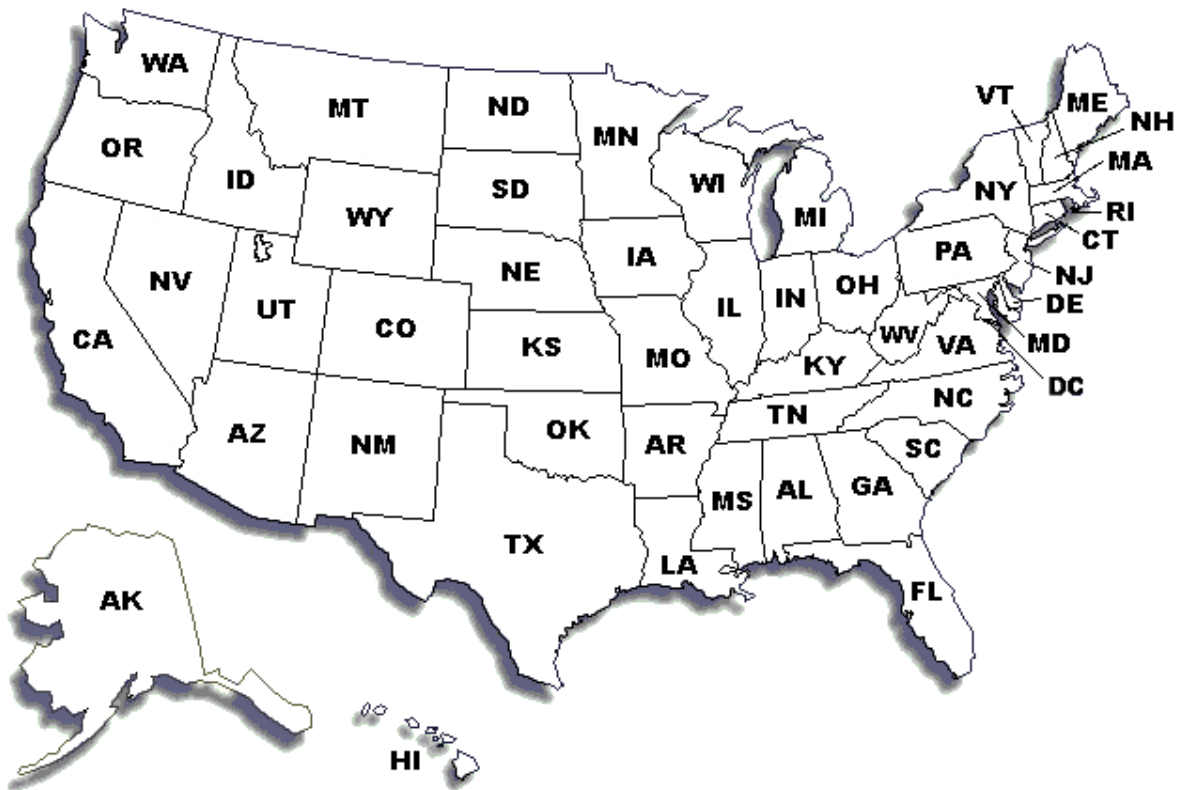

INQUIRIES AND INFORMATION:

For all other *Alfresco*[™] Gourmet Grill information such as power, installation, cut-out requirements, or any other product inquiries, please contact:

Alfresco Gourmet Grills.
Customer Service Department.
1085 Bixby Drive
City of Industry, CA. 91745

(888) 383-8800 or (323) 722-7900
(323) 726-4700. (fax)

Alfresco™ Gourmet Grills Limited Warranty

SIDE BURNERS (Residential use only)

LIMITED LIFETIME WARRANTY

Alfresco will repair or replace any stainless steel part including all fabricated stainless steel components, standard round grates (excluding what is covered in the Five Year Limited Warranty) to be defective from workmanship and when subjected to normal residential use and service. This warranty excludes surface corrosion, scratches, discoloration, weather and atmospheric related staining, and minor surface rust and oxidation which are normal conditions. Labor to remove and replace defective parts is not covered after first year of ownership. Shipping and handling cost will apply. Alfresco recommends that you use an authorized Alfresco servicer to perform such service.

LIMITED FIVE-YEAR WARRANTY

Alfresco warrants the gas valves and drip pans, to be free from defects in materials and workmanship under normal residential use for a period of five years from the original date of purchase. Labor to remove and replace defective parts is not covered after first year of ownership. Shipping and handling cost will apply. All service provided by Alfresco under this warranty must be performed by an authorized Alfresco servicer.

FULL TWO YEAR WARRANTY

For two years from the date of original installation, your Alfresco Side Burner warranty covers all parts and labor to repair or replace, under normal residential use, any part of the product that proves to be defective in materials or workmanship. All service provided by Alfresco under this warranty must be performed by an authorized Alfresco servicer, unless otherwise specified by Alfresco. Service will only be provided during normal business hours.

TERMS APPLICABLE TO EACH WARRANTY

The warranty applies only to products installed for normal residential use. The warranty applies only to products installed in any one of the fifty states of the United States, the District of Columbia or the ten provinces of Canada. This warranty does not cover any parts or labor to correct any defect caused by negligence, accident or improper use, maintenance, installation, service or repair.

SERVICE & REPLACEMENT PARTS

For quicker and easier results visit our website at: <http://www.alfrescogrills.com> or, call 866-203-5607 to report service problems and/or to obtain replacement parts for your Alfresco Side Burner. Replacement parts are shipped F.O.B. Citi of Industry, California 91745. Before calling for service, please make sure you have the following information: **Model number, serial number, date of purchase, and proof of purchase** by original owner.

Limitations & Exclusions: 1. Alfresco's warranty applies only to the original purchaser and may not be transferred. 2. Alfresco's warranty is in lieu of all other warranties, expressed or implied and all other obligations or liabilities related to the sale or use of its grill products. 3. Alfresco's warranty shall not apply and Alfresco is not responsible for damage resulting from misuse, abuse, alteration of or tampering with the appliance, accident, hostile environment, flare-up fires, improper installation, or installation not in accordance with the instructions contained in the User Manual, or the local codes. 4. Alfresco shall not be liable for incidental, consequential, special or contingent damages resulting from its breach of this written warranty or any implied warranty. 5. Some states do not allow limitations on how long an implied warranty lasts, or the exclusions of or limitations on consequential damages. This warranty gives you specific legal rights and you may have other rights, which vary from state to state. 6. No one has the authority to add to or vary Alfresco's warranty, or to create for Alfresco any other obligation or liability in connection with the sale or use of its products.

Alfresco shall not be responsible for and shall not pay for the following: 1. Installation or start-up. 2. Service by an unauthorized service provider. 3. Damage or repair due to service by an unauthorized service provider or use of unauthorized parts. 4. Improper installation. 5. Damage caused by accidents, abuse, alteration, misuse, installation that is not in accordance with the instructions contained in the User Manual, or local codes. 6. Units installed in non-residential applications such as retirement homes, restaurants, hotels, schools, etc. 7. To correct normal adjustments or settings due to improper installation, commissioning or local gas supply properties. 8. Shipping and handling costs, export duties, or installation cost. 9. The cost of service calls to diagnose trouble; or Removal or re-installation cost.

TM

Alfresco

*Alfresco*TM
Open Air Culinary Systems

AIPGSB-2 CARE & USE MANUAL
ALFRESCO GOURMET GRILLS
ALL RIGHTS RESERVED - 05/2026
SES # 195 - 0143