

56" DELUXE GRILL FEATURES

Three 18-SR stainless steel high-performance Accufire[™] main burners

Sear Zone[™] high-tech ceramic infrared burner

Integrated Mega-Drive[™] rotisserie system with dual infrared burners

Signature Taste[™] integrated smoking system with dedicated burner and drawer for wood chunks

998 sq. in. actual grilling area

3-position warming rack stores up and out of the way when rotissing

Dual-integrated high-intensity halogen lights

User-friendly push-button ignition with sealed 110V AC power source

Optional standard cart, or refrigerated base

Available in LP or Natural Gas



Built-in Model



Standard Cart



Refrigerated Cart



Insulated Jacket

AVAILABLE MODELS

Built-in Models:

ALXE-56BFG – 56" Built-in Grill, 3 Burner, Rotis, Smoker, SearZone[™]

Cart Models:

ALXE-56BFGC – 56" Cart Grill, 3 Burner, Rotis, Smoker, SearZone[™], Double Doors w/ Drawers

ALXE-56BFGR – 56" Refrigerated Cart Grill, Burner, Rotis, Smoker, SearZone[™],

1 Door and 2 Drawers are Refrigerated, and a Single Storage Door

GRILL ACCESSORIES - ALFRESCO OFFERS THE INDUSTRY'S LARGEST SELECTION OF GRILL-TRANSFORMING OPTIONS



STEAMER /FRYER / PASTA COOKER

Drops into any Alfresco grill to blanch, steam, fry, or boil. Model: AG-SF



SOLID FUEL INSERT

Transform your Alfresco gas grill into a wood-source cooking system. Model: SFI-POD



INDIRECT ROASTING POD

Turn your grill into an amazing roasting oven with the indirect roasting pod. AIC-POD



COMMERCIAL GRIDDLE

For teppanyaki, fajitas, and breakfast. Side Burner Model: AGSB-G, Grill Model: AGSQ-G



DUAL SIDE BURNER

Features two burners each rated for 20,000 BTUs, and easily attaches to any Alfresco cart model grill for added cooking versatility. AXESB-2C (Cart)

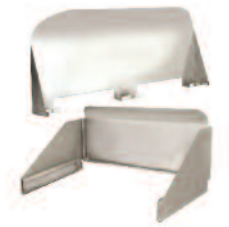

WIND GUARDS

For windy exposed environments that may affect cooking performance and consistency. AWS-56 (Built-in), AWS-56C (Cart)



GRILL COVERS

Available in standard high-density canvas or premium PVC leather with felt lining and -25°C cold resistance, Alfresco grill covers provide year-round protection for built-in and cart grills.

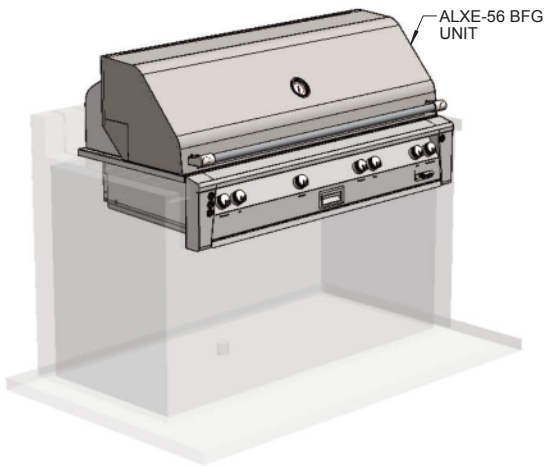

TYPICAL ALXE-56 BFG INSTALLATION

COUNTERTOP CUTOUT REQUIREMENTS

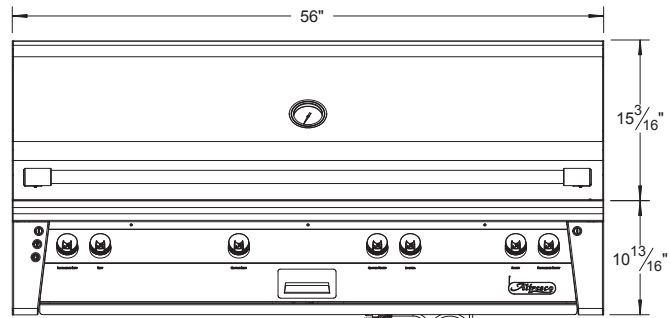
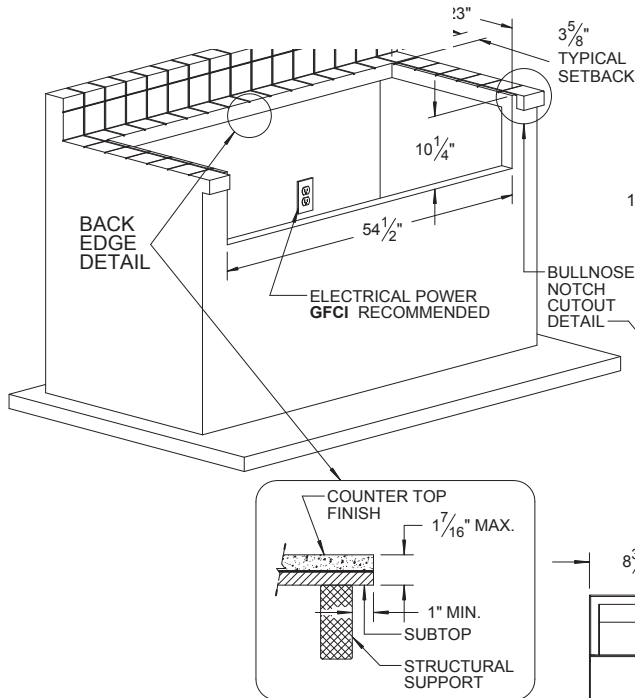

UNIT SUPPLIED WITH 8 FT. NEMA 5-15 ELECTRICAL PLUG

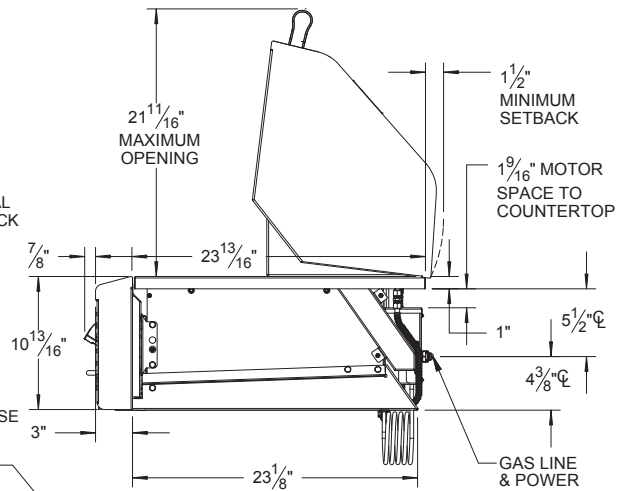

DEPTH EQUAL TO BULLNOSE OVERHANG

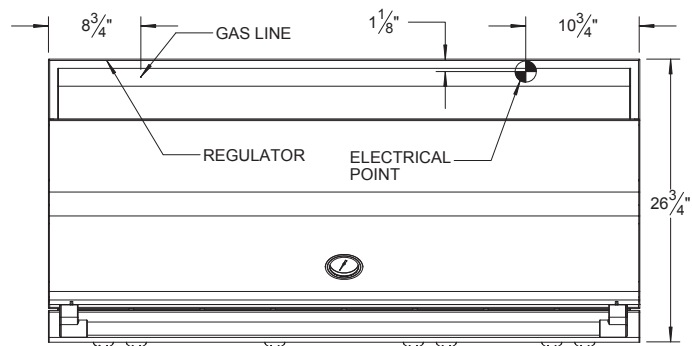
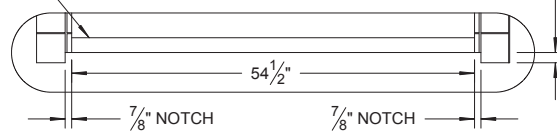

SHOWN WITHOUT SIDE BURNER COVER

NOTE:

- Cutout shown for non-combustible construction only. Otherwise, use of AU-56 is required.
- Counter must have proper gas and power supplies for your Alfresco BBQ.

SPECIFICATIONS:

- BTUH = 148,000
- Fuel = NG @ 5" W.C. or LP @ 10" W.C.
- Electrical Power = 115 VAC / 1.44 A / 60Hz.
- Gas Connection = 1/2" NPT (NG) or 3/8" ODF (LP)

Alfresco Authorized Dealer:

Project/Client:

Date:

Contact: