

GRILLS & INSULATED JACKETS

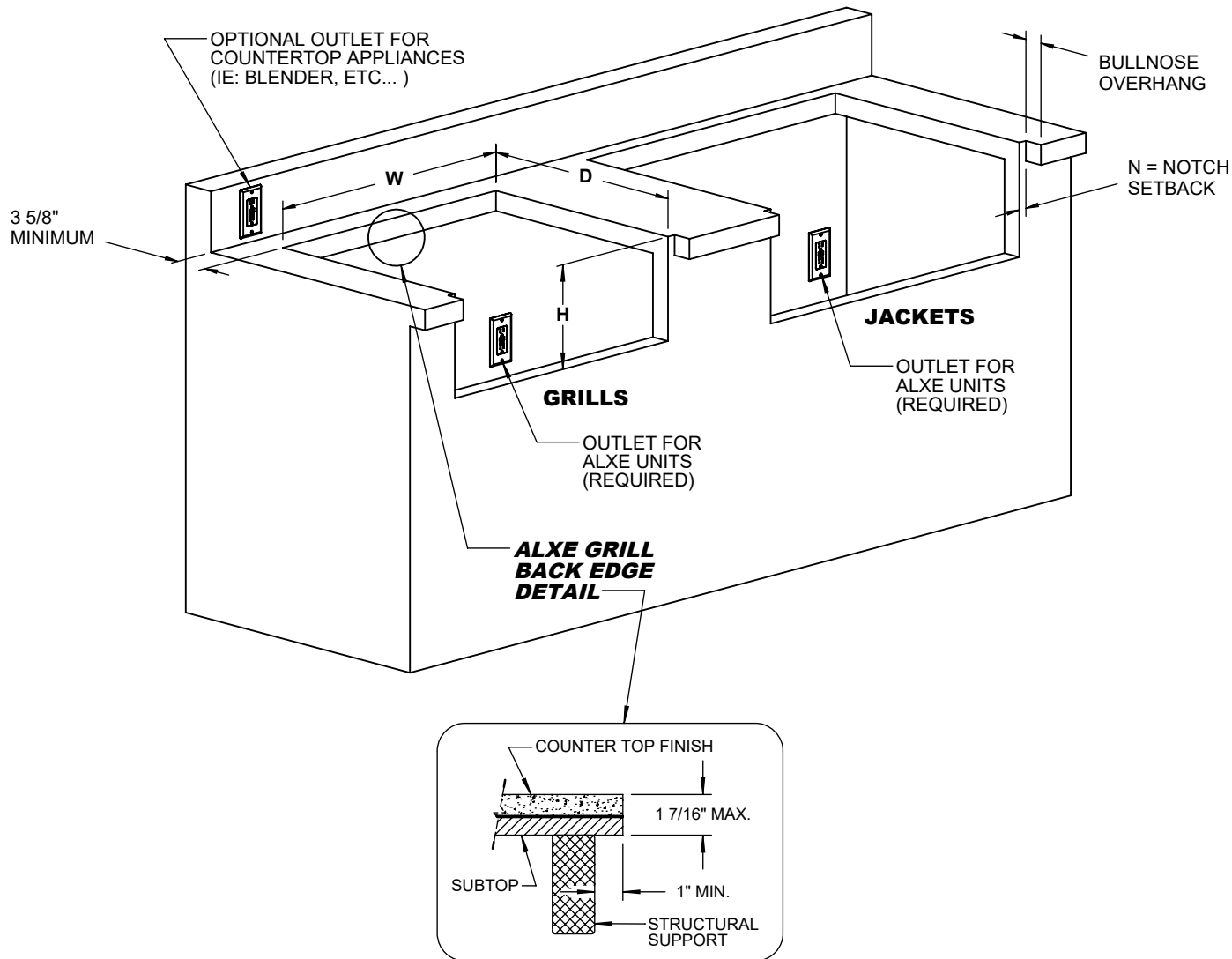

MODEL	CUTOUT DIMENSIONS			NOTCH N	POWER			GAS LINE
	W	D	H		YES	NO	AMPS	
ALXE-30	28-1/2"	23"	10-1/4"	7/8"	✓		1.44 / 0.91	✓
ALXE-36	34-1/2"	23"	10-1/4"	7/8"	✓		1.44 / 0.91	✓
ALXE-42	40-1/2"	23"	10-1/4"	7/8"	✓		1.44 / 0.91	✓
ALXE-56 / -56 BFG	54-1/2"	23"	10-1/4"	7/8"	✓		1.44 / 0.91	✓
AIJ-30	33-1/4"	24-5/8"	11-1/4"	7/8"	✓		◆	✓
AIJ-36	39-1/4"	24-5/8"	11-1/4"	7/8"	✓		◆	✓
AIJ-42	45-1/4"	24-5/8"	11-1/4"	7/8"	✓		◆	✓
AIJ-56	59-1/4"	24-5/8"	11-1/4"	7/8"	✓		◆	✓

NOTE 1: ALL GRILLS REQUIRE A 1/2" NPT GAS CONNECTION WITH 5" WC FOR NATURAL GAS AND 10" WC FOR LIQUID PROPANE.

NOTE 2: ALL POWER SUPPLIES ARE 115 VAC-1Ø- 60 Hz. **GFCI** RECEPTACLE RECOMMENDED.

NOTE ◆: POWER REQUIREMENT AS STATED ON THE CORRESPONDING GRILL (NOT DUE TO THE AIJ JACKET BY ITSELF).

FRONT MOUNTED ISLAND ACCESSORIES, PANTRIES, DOORS, DRAWERS AND COMBO UNITS

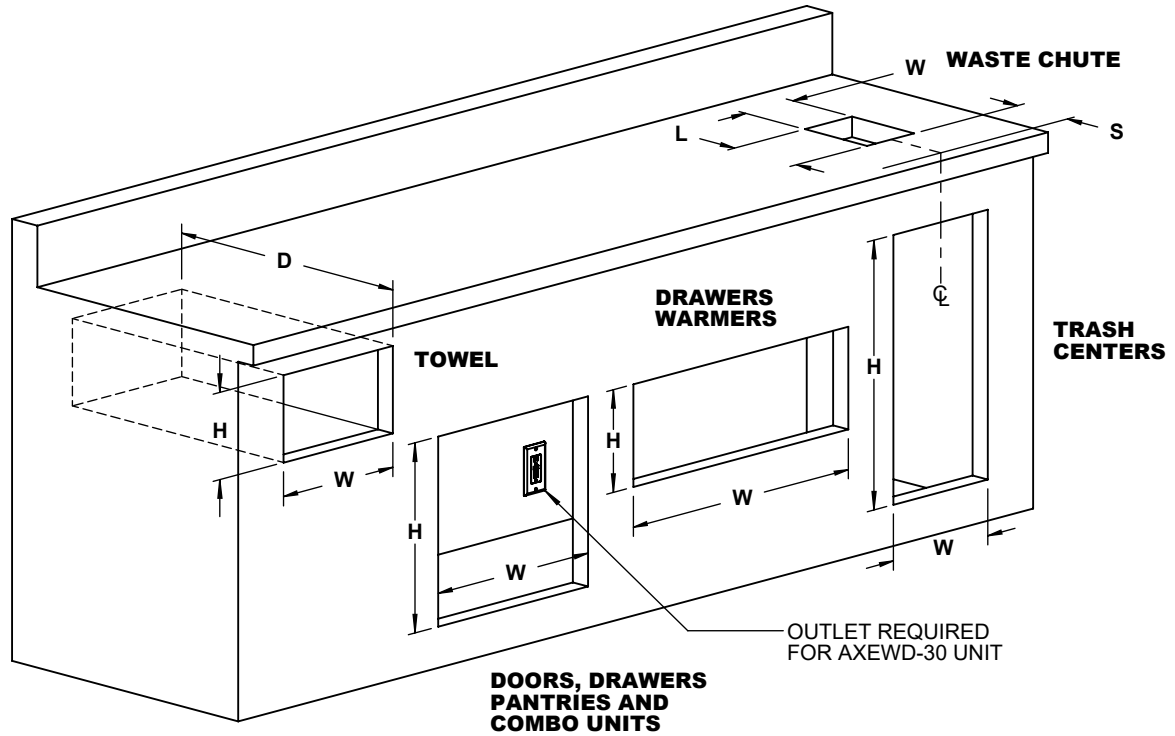

MODEL	CUTOUT DIMENSIONS				SETBACK S	POWER			DRAIN LINE
	W	H	D	L		YES	NO	AMPS	
AXE-17L / -17R / -17E	13-7/8"	18-1/2"	21-5/8"			✓			
AXE-23L / -23R / -23E	19-7/8"	18-1/2"	21-5/8"			✓			
AXE-30 / -30E	27-1/4"	18-1/2"	21-5/8"			✓			
AXE-36 / -36E	33-1/4"	18-1/2"	21-5/8"			✓			
AXE-42 / -42E	39-1/4"	18-1/2"	21-5/8"			✓			
AXE-DDC-L-SC / -R-SC	29-3/8"	18-5/8"	19-3/8"			✓			
AXE-DDR-L-SC / -R-SC	14-3/8"	26-1/4"	19-3/8"			✓			
AXE-DTH-L / -R	14-3/8"	26-1/4"	8-1/4"			✓			
AXE-3DRTH-SC	14-3/8"	26-1/4"	19-3/8"			✓			
AXE-2DR-SC	14-5/8"	12-1/4"	19-3/8"			✓			
AXE-3DR-SC	14-5/8"	18-5/8"	19-3/8"			✓			
AXE-30DR-SC	27-3/4"	14"	23-7/8"			✓			
AXE-ID	24"	17-3/4"	25-1/8"			✓		5/8" ⚡	
AXE-TC-SC	12-1/2"	26-1/4"	18-1/2"			✓			
AXE-TC2-SC	23-7/8"	26-1/4"	18-1/2"			✓			
AXE-TC2D-SC	17-1/4"	26-1/4"	24-1/2"			✓			
AXE-TH	14-1/2"	8-1/2"	7-7/8"			✓			
AXEDSP-30H	28-3/8"	31-3/4"	23-7/8"			✓			
AXEDSP-30L	28-3/8"	19-3/8"	23-7/8"			✓			
AXEDSP-36L	34-3/8"	19-3/8"	23-7/8"			✓			
AXEDSP-42H	40-3/8"	31-3/4"	23-7/8"			✓			
AXEDSP-42L	40-3/8"	19-3/8"	23-7/8"			✓			
APWC	6-1/4"	~	~	8-1/4"	4-5/8" ◆		✓		
AXEWD-30	28-1/2"	10"	20-5/8"			✓		3.9	

NOTE: ALL POWER SUPPLIES ARE 115 VAC-1Ø- 60 Hz. **GFCI** RECEPTACLE RECOMMENDED.

NOTE ◆: SETBACK MEASURED FROM CABINET FACE (NOT BULLNOSE!).

NOTE ⚡: AB-ID UNIT COMES WITH 36" PLASTIC DRAIN HOSE FOR CONDENSATE/ ICE WATER WASTE.

COUNTERTOP ACCESSORIES

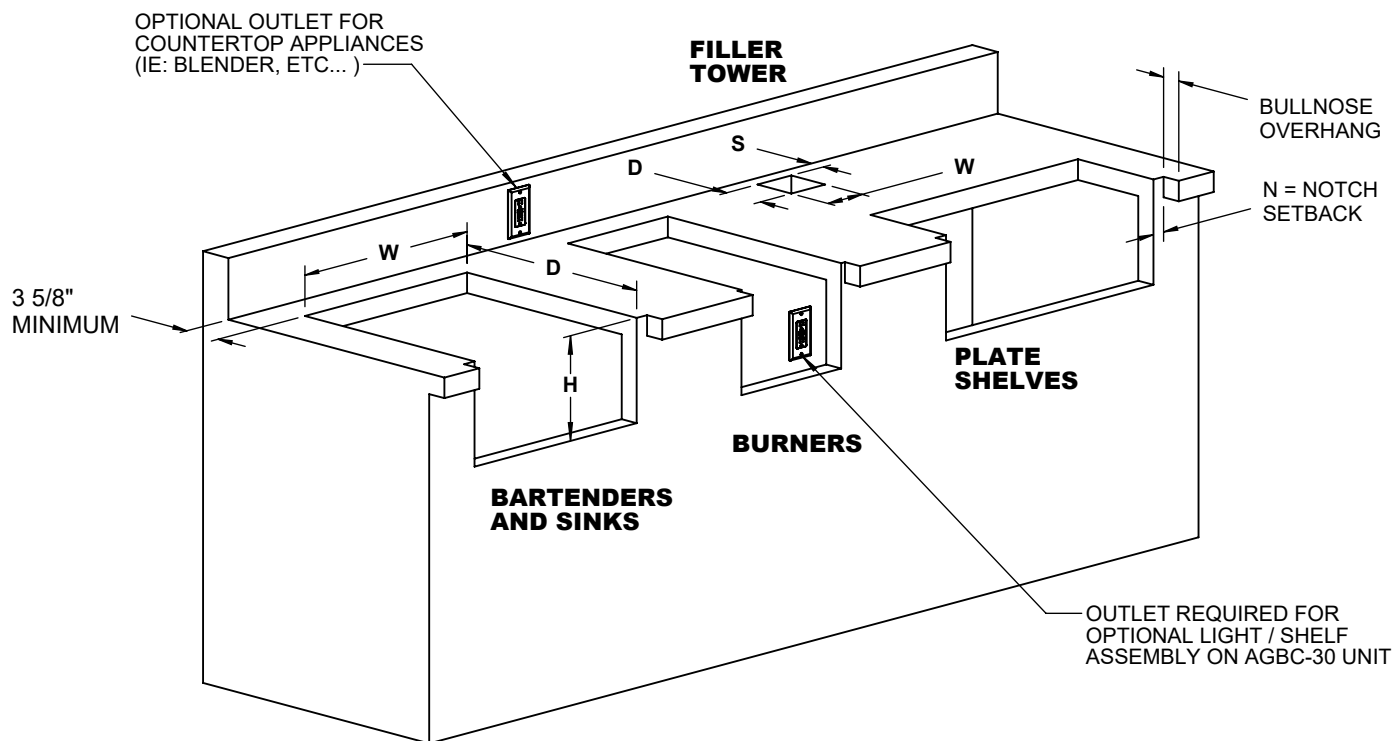

MODEL	CUTOUT DIMENSIONS			NOTCH N	SETBACK S	POWER			GAS LINE	WATER LINE	DRAIN LINE
	W	D	H			YES	NO	AMPS			
AXEVP	21-1/2"	22-1/2"	10-1/4"	1-3/8"		✓		10 mA	✓		
AXEVP-T10	4-1/2"	4-1/2"			1-5/8" ❖		✓			3/8" ⚙	
AXESB-2	13-1/4"	23"	10"	1/2"		✓		10 mA	✓		
AXESZ	13-1/4"	23"	10-1/4"	1/2"		✓		10 mA	✓		
AXEFW	13-1/4"	23"	10-1/4"	1/2"			✓				
AGBC-14	13-1/4"	23"	9-1/4"	1/2"			✓				1-1/2"
AGBC-24	22-1/2"	23-1/4"	9"	7/8"			✓				1-1/2"
AGBC-30	28-1/2"	23-1/4"	9"	7/8"			✓				1-1/2"
ASK-T	13-1/4"	23"	10-1/4"	1/2"			✓			1/2"	1"
APS-30P	26-7/8"	15-1/4"	9"	1-7/8"			✓				
APS-30PPC	26-7/8"	22-1/2"	9"	1-7/8"			✓				

NOTE 1: ALL BURNERS REQUIRE A 1/2" NPT GAS CONNECTION WITH 4" WC FOR NATURAL GAS AND 10" WC FOR LIQUID PROPANE.

NOTE 2: ALL WATER LINES ARE 3/8" COMPRESSION OR 1/2" NPSM UNLESS OTHERWISE SHOWN.

NOTE 3: ALL DRAINS SIZES AS SHOWN ARE NPSM STANDARD.

NOTE 4: ALL POWER SUPPLIES ARE 115 VAC-1Ø- 60 Hz. **GFCI** RECEPTACLE RECOMMENDED.

NOTE ❖: THE AGVPC-T10 POT FILLER TOWER REQUIRES A MINIMUM SETBACK AS SHOWN (OVER AND UNDER THE COUNTER) FROM THE BACK WALL FOR PROPER HARDWARE INSTALLATION.

NOTE ⚙: THE AGVPC-T10 POT FILLER TOWER REQUIRES A 3/8" COMPRESSION WATER LINE AND COMES WITH A 72" LONG COPPER LINE FOR FIELD CONNECTION.

REFRIGERATORS

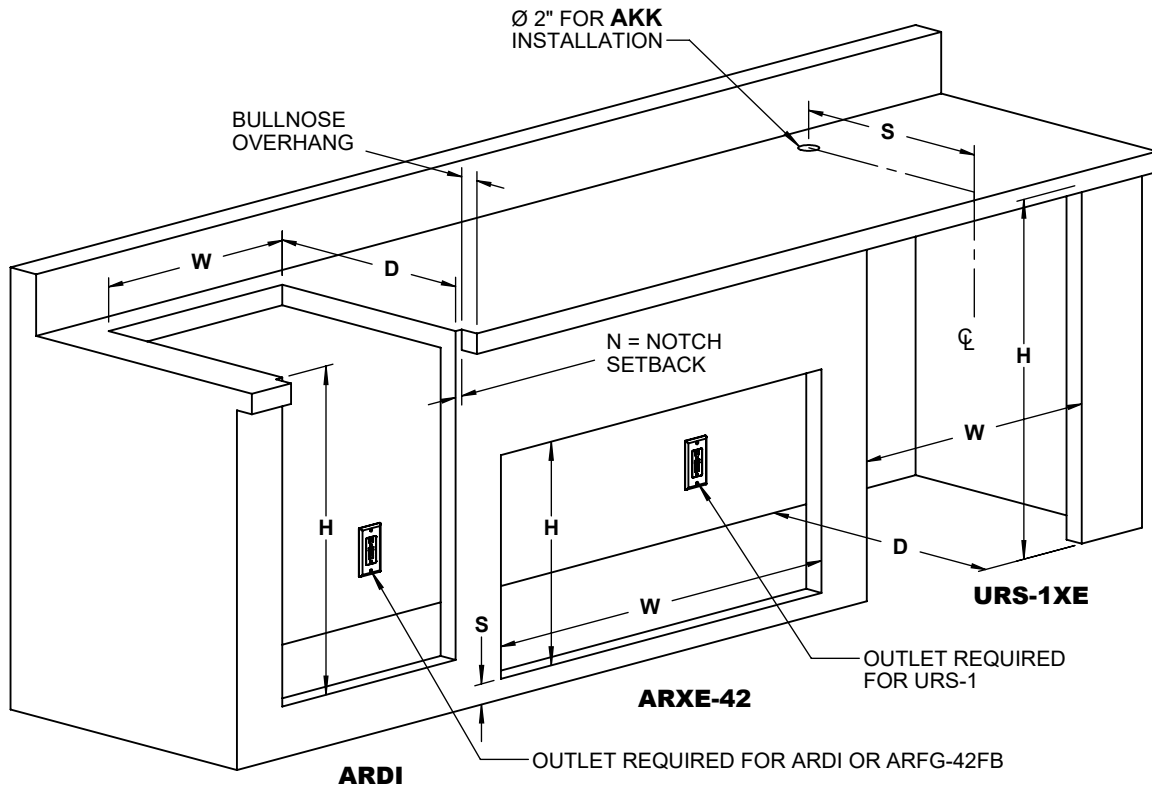

MODEL	DIMENSIONS			NOTCH N	SETBACK S	POWER			DRAIN LINE
	W	H	D			YES	NO	AMPS	
AKK	2" DIAMETER HOLE				21-15/16" ❖		✓		
ARXE-42	42-1/2"	21-3/4"	23-1/4"		2" ◆	✓		2.9	
URS-1XE	28-1/2"	35"	23-3/8"			✓		2.8	

NOTE: ALL POWER SUPPLIES ARE 115 VAC-1Ø- 60 Hz. **GFCI** RECEPTACLE RECOMMENDED.

NOTE ❖: SETBACK MEASURED FROM CABINET FRONT (NOT BULLNOSE!)

NOTE ⚙: DRAIN SIZE IS NPSM - FLOOR DRAIN IN LIEU OF WALL MOUNT IS ACCEPTABLE.

NOTE ◆: SETBACK MINIMUM DISTANCE FROM FLOOR TO ACCOMODATE ARFG-42 PERIMETER FLANGE.

PIZZA BUILT-IN UNIT

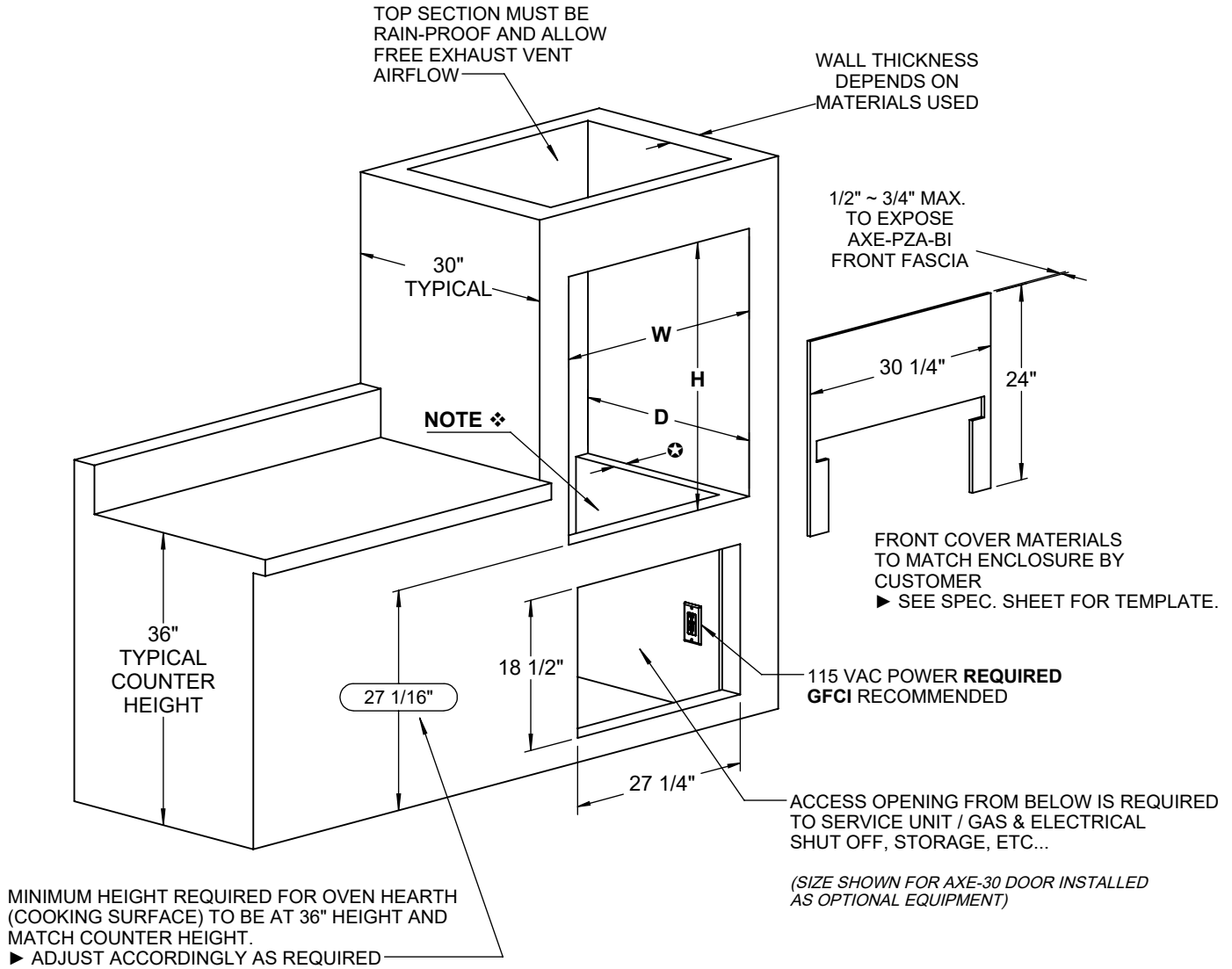

MODEL	DIMENSIONS			NOTCH	SETBACK	POWER 115 VAC			DRAIN LINE
	W	H	D			YES	NO	AMPS	
AXE-PZA-BI	30-1/4"	33"	27"	~	~	✓		0.3 A	NO

NOTES:

- ❖ A 2" WIDE LEDGE IS REQUIRED TO SUPPORT THE AXE-PZA-BI UNIT ON BOTH LEFT AND RIGHT SIDES OF THE OPENING.
- ❖ OPENING AT THE BOTTOM OF THE AXE-PZA-BI UNIT IS REQUIRED FOR COMBUSTION AIR. COUNTER MUST HAVE AIR INTAKE OR VENTILATION FOR PROPER OPERATION.
- ▶ REFER TO SPECIFICATION SHEET AND MANUAL FOR COMPLETE INSTALLATION GUIDELINES.
- ▶ REFER TO SPECIFICATION SHEET FOR FULL SIZE FRONTAL CUTOUT TEMPLATE..