

# GRILLS & INSULATED JACKETS

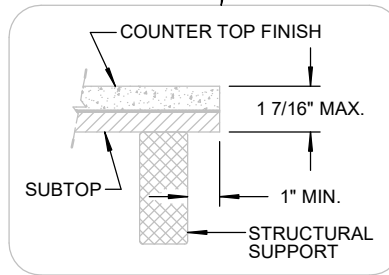
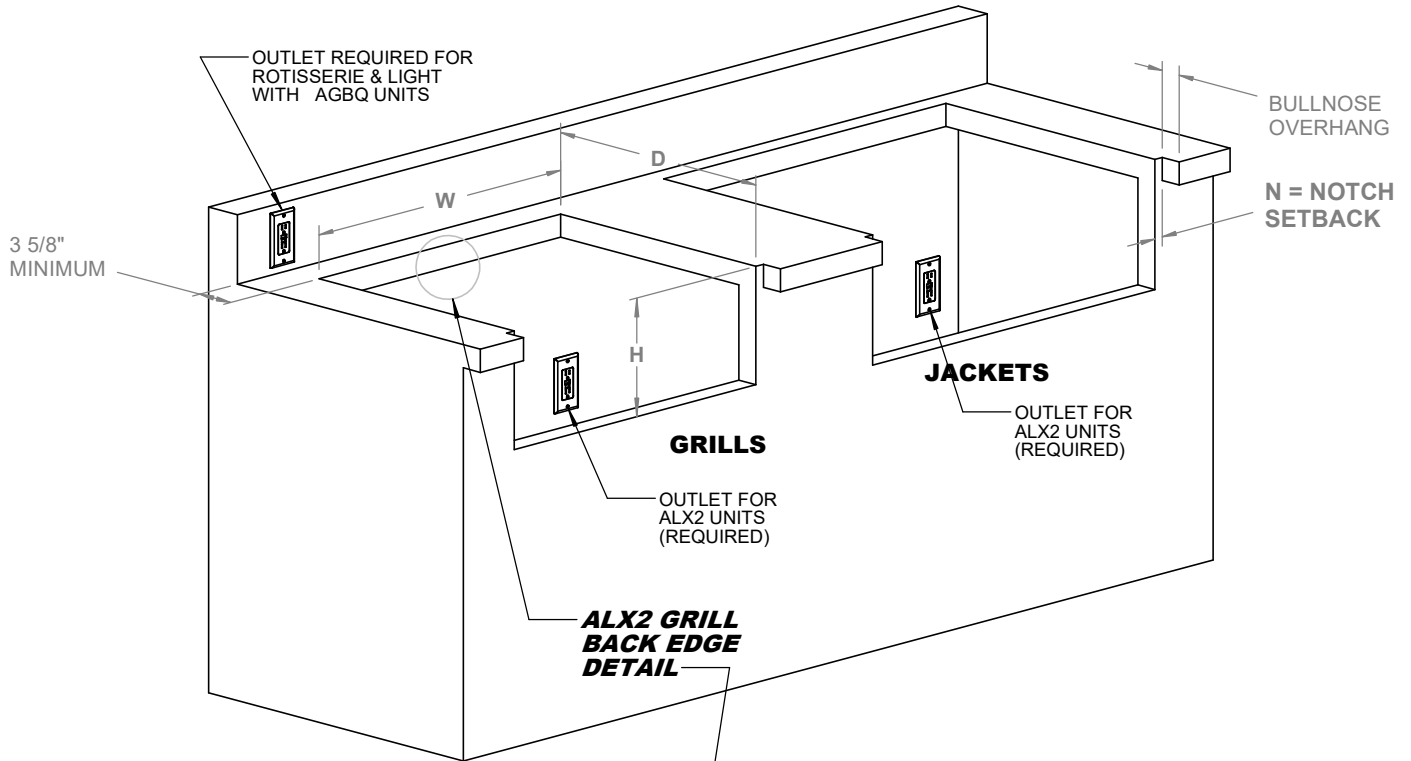

MODEL	CUTOUT DIMENSIONS			NOTCH N	POWER			GAS LINE
	W	D	H		YES	NO	AMPS	
ALX2 / AGBQ-30	28-1/2"	23"	10-1/4"	7/8"	✓		1.44 / 0.91	✓
ALX2-36	34-1/2"	23"	10-1/4"	7/8"	✓		1.44 / 0.91	✓
ALX2 / AGBQ-42	40-1/2"	23"	10-1/4"	7/8"	✓		1.44 / 0.91	✓
ALX2 / AGBQ-56	54-1/2"	23"	10-1/4"	7/8"	✓		1.44 / 0.91	✓
AIJ-30	33-1/4"	24-5/8"	11-1/4"	7/8"	✓		◆	✓
AIJ-36	39-1/4"	24-5/8"	11-1/4"	7/8"	✓		◆	✓
AIJ-42	45-1/4"	24-5/8"	11-1/4"	7/8"	✓		◆	✓
AIJ-56	59-1/4"	24-5/8"	11-1/4"	7/8"	✓		◆	✓

**NOTE 1:** ALL GRILLS REQUIRE A 1/2" NPT GAS CONNECTION WITH 4" WC FOR NATURAL GAS AND 10" WC FOR LIQUID PROPANE.

**NOTE 2:** ALL POWER SUPPLIES ARE 115 VAC-1Ø- 60 Hz. **GFCI** RECEPTACLE RECOMMENDED.

**NOTE ◆:** POWER REQUIREMENT AS STATED ON THE CORRESPONDING GRILL (NOT DUE TO THE AIJ JACKET BY ITSELF).

# FRONT MOUNTED ISLAND ACCESSORIES, PANTRIES, DOORS, DRAWERS AND COMBO UNITS

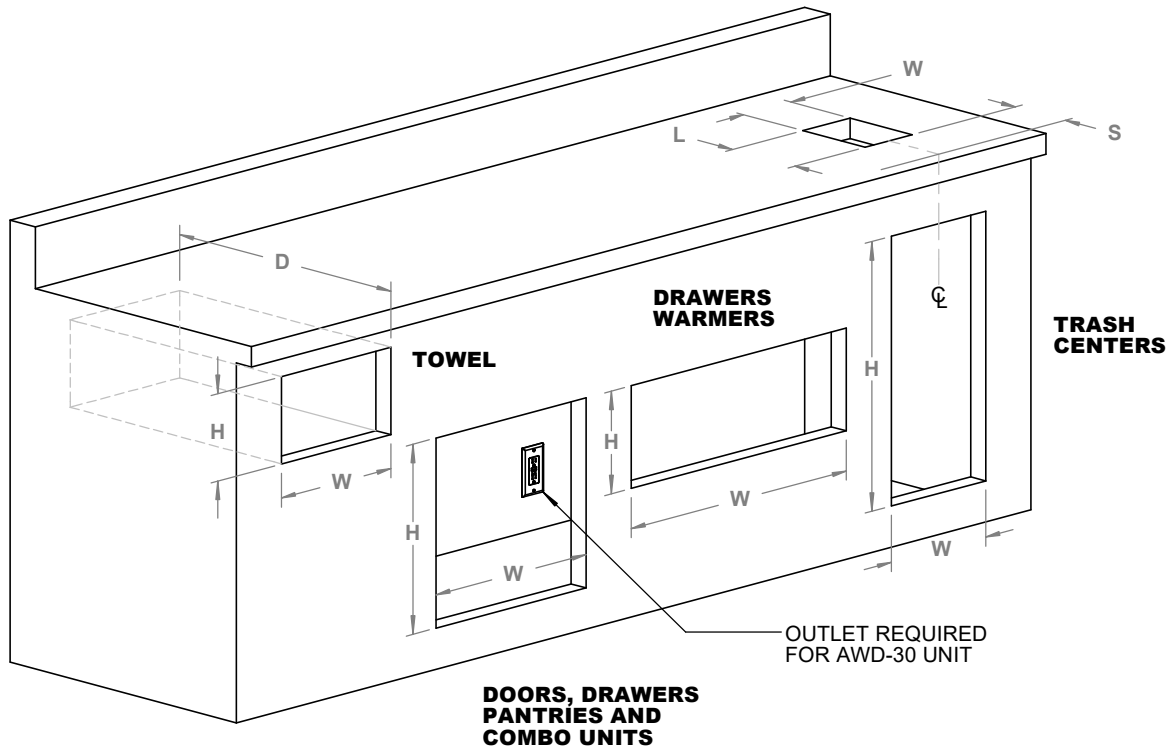

MODEL	CUTOUT DIMENSIONS				SETBACK S	POWER			DRAIN LINE
	W	H	D	L		YES	NO	AMPS	
AB-17L / AB-17R	13-7/8"	18-1/2"	~				✓		
AB-23L / AB-23R	19-7/8"	18-1/2"	~				✓		
AB-30	27-1/4"	18-1/2"	~				✓		
AB-42	39-1/4"	18-1/2"	~				✓		
AB-DDC-L / AB-DDC-R	29-3/8"	18-5/8"	19-1/4"				✓		
AB-2DR	14-5/8"	12-1/4"	19-1/4"				✓		
AB-3DR	14-5/8"	18-5/8"	19-1/4"				✓		
AB-30DR	27-3/4"	14"	23-3/4"				✓		
AB-ID	24"	17-3/4"	25-1/8"				✓		5/8" ⚡
AB-TC (TRASH ONLY)	12-1/2"	26-1/4"	18-1/2"				✓		
AB-TC2 (TRASH & RECYCLE)	23-7/8"	26-1/4"	18-1/2"						
AB-TH	14-1/2"	8-1/2"	7-7/8"				✓		
ADSP-30H	28-3/8"	31-3/4"	23-3/8"				✓		
ADSP-30L	28-3/8"	19-3/8"	23-3/8"				✓		
ADSP-42H	40-3/8"	31-3/4"	23-3/8"				✓		
ADSP-42L	40-3/8"	19-3/8"	23-3/8"				✓		
APWC (CHUTE ONLY)	6-1/4"	~	~	8-1/4"	4-5/8" ◆		✓		
AWD-30	28-1/2"	10"	20-1/4"				✓	3.9	

**NOTE:** ALL POWER SUPPLIES ARE 115 VAC-1Ø- 60 Hz. **GFCI** RECEPTACLE RECOMMENDED.

**NOTE ◆:** SETBACK MEASURED FROM CABINET FACE (NOT BULLNOSE!).

**NOTE ⚡:** AB-ID UNIT COMES WITH 36" PLASTIC DRAIN HOSE FOR CONDENSATE/ ICE WATER WASTE.

# COUNTERTOP ACCESSORIES

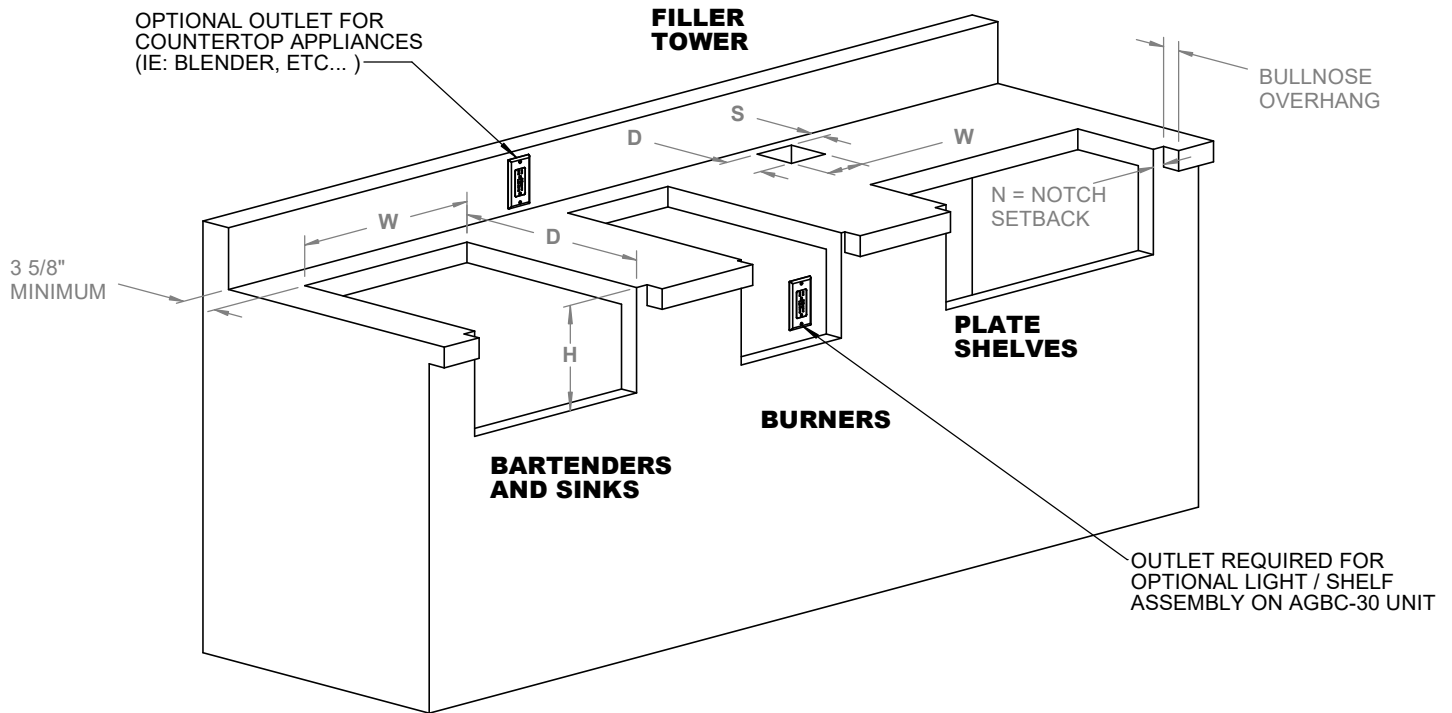

MODEL	CUTOUT DIMENSIONS			NOTCH N	SETBACK S	POWER			GAS LINE	WATER LINE	DRAIN LINE
	W	D	H			YES	NO	AMPS			
AGVPC	21-1/2"	22-1/2"	10-1/4"	1-3/8"			✓		✓		
AGVPC-T10	4-1/2"	4-1/2"			1-5/8" ❖		✓			3/8" Ⓞ	
AGSB / AGSZ	13-1/4"	23"	10-1/4"	1/2"			✓		✓		
AFW	13-1/4"	23"	10-1/4"	1/2"			✓				
ADT-14	13-1/4"	23"	9-1/4"	1/2"			✓			1/2"	1" + 2"
ADT-24	23-1/4"	23"	10-1/4"	1/2"			✓				1"
ADT-30	28-1/2"	23"	10-1/4"	3/4"			✓			1/2"	1" + 2"
AGBC-14	13-1/4"	23"	9-1/4"	1/2"			✓				1-1/2"
AGBC-24	22-1/2"	23-1/4"	9"	7/8"			✓				1-1/2"
AGBC-30	28-1/2"	23-1/4"	9"	7/8"		✓		0.08			1-1/2"
ASK-T	13-1/4"	23"	10-1/4"	1/2"			✓			1/2"	1"
APS-30	26-7/8"	7-1/4"	9"	1-7/8"			✓				
APS-30P	26-7/8"	15-1/4"	9"	1-7/8"			✓				
APS-30PPC	26-7/8"	22-1/2"	9"	1-7/8"			✓				

**NOTE 1:** ALL BURNERS REQUIRE A 1/2" NPT GAS CONNECTION WITH 4" WC FOR NATURAL GAS AND 10" WC FOR LIQUID PROPANE.

**NOTE 2:** ALL WATER LINES ARE 3/8" COMPRESSION OR 1/2" NPSM UNLESS OTHERWISE SHOWN.

**NOTE 3:** ALL DRAINS SIZES AS SHOWN ARE NPSM STANDARD.

**NOTE 4:** ALL POWER SUPPLIES ARE 115 VAC-1Ø- 60 Hz. **GFCI** RECEPTACLE RECOMMENDED.

**NOTE ❖:** THE AGVPC-T10 POT FILLER TOWER REQUIRES A MINIMUM SETBACK AS SHOWN (OVER AND UNDER THE COUNTER) FROM THE BACK WALL FOR PROPER HARDWARE INSTALLATION.

**NOTE Ⓞ:** THE AGVPC-T10 POT FILLER TOWER REQUIRES A 3/8" COMPRESSION WATER LINE AND COMES WITH A 72" LONG COPPER LINE FOR FIELD CONNECTION.

# REFRIGERATORS

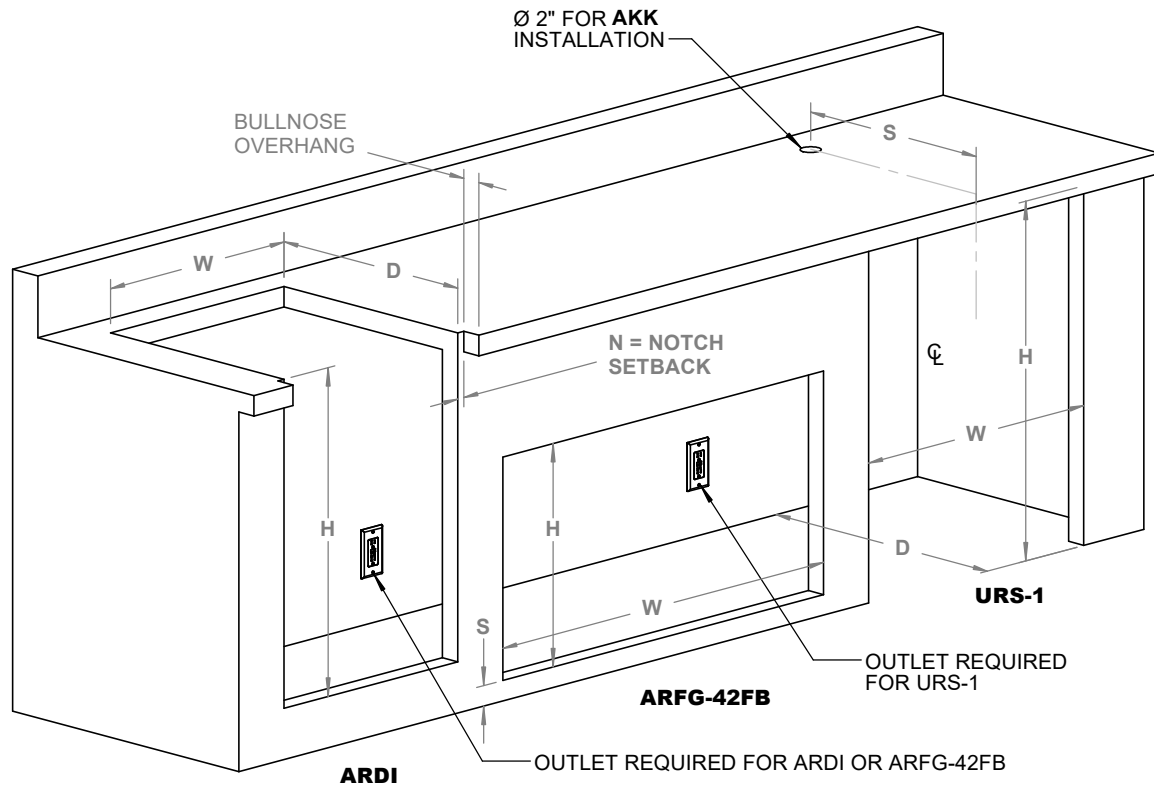

MODEL	DIMENSIONS			NOTCH N	SETBACK S	POWER			DRAIN LINE
	W	H	D			YES	NO	AMPS	
AKK	2" DIAMETER HOLE				21-15/16" ❖		✓		
ARDI	23"	32"	23"	13/16"		✓		5.7	1" Ⓢ
ARFG-42FB	42-1/2"	21-3/4"	23-1/4"		2" ◆	✓		2.9	
URS-1	28-1/2"	35"	23-3/8"			✓		2.8	

**NOTE:** ALL POWER SUPPLIES ARE 115 VAC-1Ø- 60 Hz. **GFCI** RECEPTACLE RECOMMENDED.

**NOTE** ❖: SETBACK MEASURED FROM CABINET FRONT (NOT BULLNOSE!)

**NOTE** Ⓢ: DRAIN SIZE IS NPSM - FLOOR DRAIN IN LIEU OF WALL MOUNT IS ACCEPTABLE.

**NOTE** ◆: SETBACK MINIMUM DISTANCE FROM FLOOR TO ACCOMODATE ARFG-42 PERIMETER FLANGE.