

REMOVABLE SHELVES

GAS TANK SHOWN AS REFERENCE (CUSTOMER SUPPLIED)

GAS TANK SLIDING SHELF INCLUDED

**SPECIFICATIONS:**

BTUH: 60,000  
 FUEL: NG @ 5 W.C. OR LP @ 10 W.C.  
 ELECTRICAL POWER: 9 VDC IGNITION SYSTEM  
 GAS CONNECTION: 1/2" NPT (NG) OR 3/8" ODF (LP)

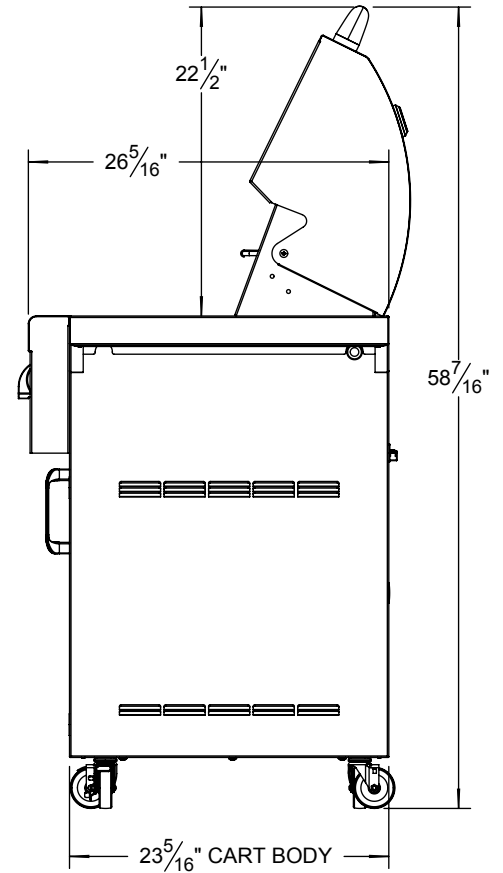
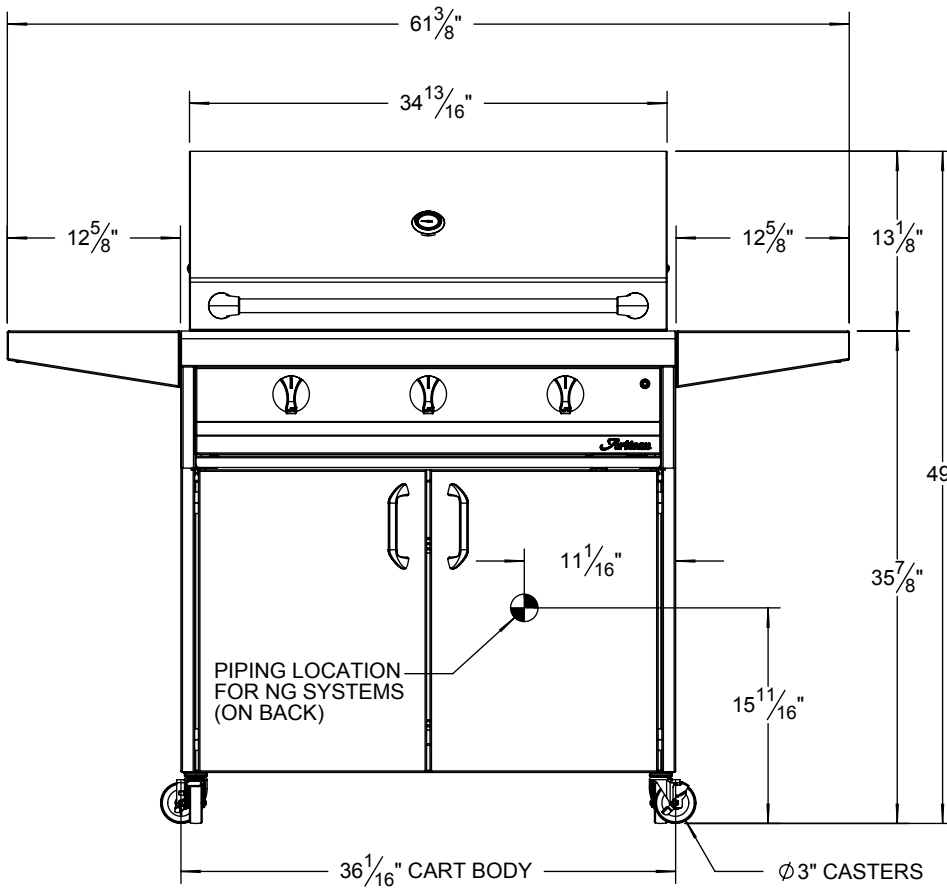

**Artisan**

THE INFORMATION CONTAINED IN THIS DRAWING IS THE SOLE PROPERTY OF SUPERIOR EQUIPMENT SOLUTIONS INC. ANY REPRODUCTION IN PART OR AS A WHOLE WITHOUT WRITTEN PERMISSION FROM SUPERIOR EQUIPMENT SOLUTIONS, INC. IS PROHIBITED.

PROJECT TITLE:  
**ARTISAN GRILLS**

DRAWING NO.:  
**AAE-36C SPEC SHEET**

DRAWN BY: ADRIAN CRISCI  
 CREATED: 3/19/2013 1:18:24 PM

DRAWING TITLE:  
**AAE-36C CART+ BBQ ASSEMBLY**