

TM

AlfrescoTM

Open Air Culinary Systems



ALX2-56 BFG Parts Manual

For models S/N: 11-00000 forward.

BILL OF MATERIALS

ITEM	PART N°	DESCRIPTION	QTY
1	100-1877	ALX2 - ROTISSERIE CHAIN COVER	1
2	200-0057	SCREW 1/4-20 X 1/2 - TRUSS HEAD - PHILPS	15
3	200-0087	WASHER - 1/4" SPRING LOCK- REGULAR - SS	10
4	200-0089	BOLT - HEX HEAD 1/4-20 x 1/2" L	10
5	200-0093	WASHER - PUSH LOCK 1/8" ID X 3/8" OD (LOGO)	2
6	200-0111	SCREW 8-18 X 1/2 - SELF TAP - 410 SS	4
7	200-0244	WASHER, FLAT 1/4 TYPE B - REGULAR, SS	4
8	290-0031	LOGO - ALFRESCO	1
9	290-0038	BURNER - GRILL - "U" SHAPE	3
10	290-0052	ALFRESCO SEAR ZONE™ BURNER ASSEMBLY	1
11	290-0059	ROTISSERIE DRIP PAN	2
12	290-0096	FORK ASSEMBLY	4
13	290-0116	CHAIN - ANSI # 25 - 1/4" PITCH - .13" Ø X 1/8" ROLLER	1
14	290-0124	GRILL 30" BBQ - 12 3/4" WIDE - SS	3
15	290-0176	ALX2-56 BFG ROTISSERIE SPEAR	1
16	290-0315	ALX2-30 WARMING RACK - SS	2
17	510-0468	ALX2-56BFG MANIFOLD ASSEMBLY	1
18	510-0490	ALX2-56 / 56SZ - GREASE TRAY ASSEMBLY	1
19	510-0497	ALX2-56 BFG - ELECTRICAL COMPONENTS	1
20	510-0504	ALX2 - SMOKER BURNER ASSEMBLY	1
21	510-0518	ALX2 - SMOKER TRAY ASSEMBLY	1
22	510-0521	ALX2 - SEARZONE™ GRILL ASSEMBLY	1
23	510-0522	ALX2 - BRIQUETTE TRAY ASSEMBLY	3
24	510-0580	ALX2-56BFG - FIREBOX ASSEMBLY	1
25	510-0581	ALX2-56 BFG - FRONT PANEL MAIN ASSEMBLY	1
26	510-0582	ALX2-56 BFG BACK HOOD + RIM ASSEMBLY	1
27	510-0585	ALX2-56 BFG FRONT HOOD - MAIN ASSEMBLY	1

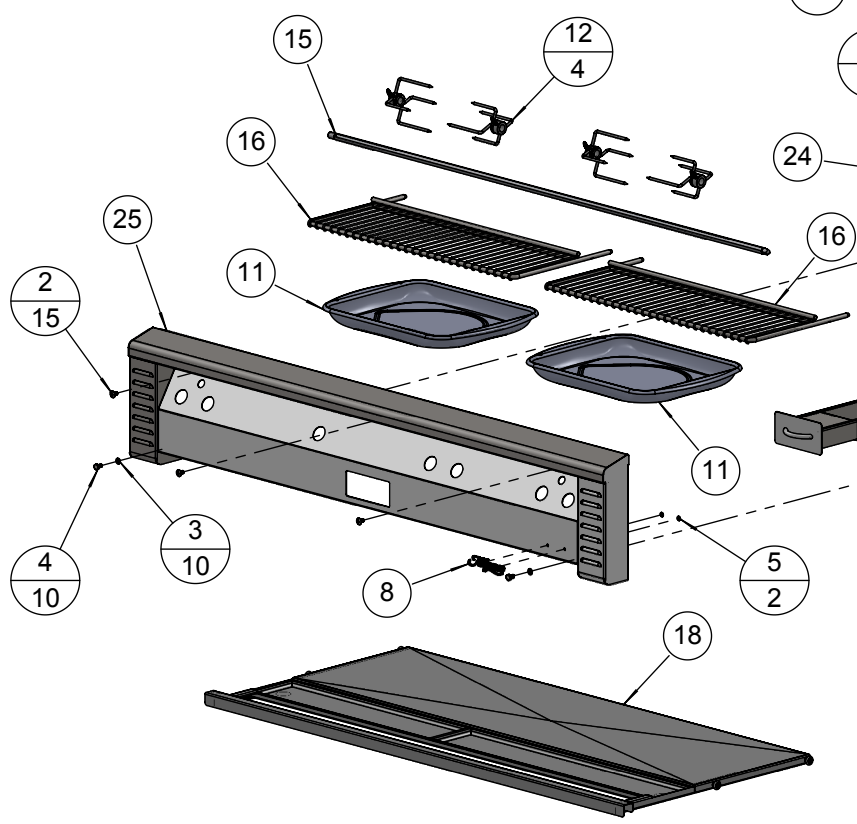
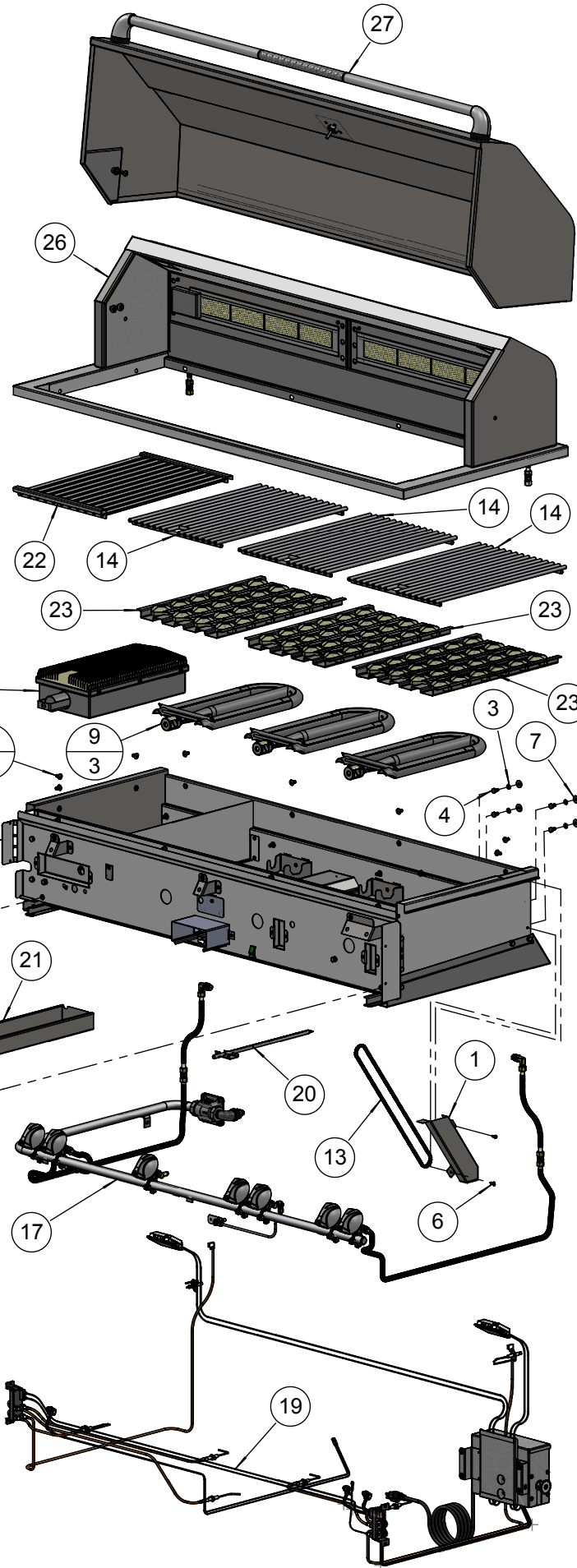

BILL OF MATERIALS

ITEM	PART N°	DESCRIPTION	QTY
1	100-0913	30" & 56" BFG BBQ SMOKER GAS LINE	1
2	100-0917	ROTISSERIE GAS LINE EXTENSION - 3/8"Ø X 8" - SS	2
3	100-0917	SEAR ZONE™ GAS LINE (8"L x 3/8" Ø - SS. FLEX TUBE)	1
4	100-0949	ROTISSERIE GAS LINE (36"L x 3/8" Ø - SS. FLEX TUBE)	1
5	100-1067	ALX2- SMOKER & SZ™ ORIFICE BRACKET	2
6	100-1949	ROTISSERIE GAS LINE (36"L x 3/8" Ø - SS. FLEX TUBE)	1
7	200-0274	ELBOW 90°- CAST IRON - 1/2" FPT x 1/2" MPT	1
8	220-0151	COUPLING 3/8" x 3/8" - COMPRESSION - BRASS	2
9	220-0273	ELBOW 90° - 1/8" FPT x 3/16" COMP	2
10	220-0275	NIPPLE - 1/2" MPT X 3/8" OD FL	1
11	220-0276	ELBOW .375 MPT x .375 COMP	2
12	220-0277	NIPPLE 1/8"MPT x 1/16"MPT	1
13	220-0280	REGULATOR GAS - MAXITROL RV48CL440002	1
14	220-0293	ELBOW 3/8-27 UNS x 3/8" COMP	1
15	220-0349	MANIFOLD - ALX2-56" BFG	1
16	290-0030	KNOB BBQ - ALFRESCO "A" LETTER	7
17	290-0041	GAS VALVE - STRAIGHT - WITHOUT ORIFICES	3
18	290-0066	GAS VALVE - ANGLED - ORIFICE: INT= 0.95 mm / EXT=NONE	1
19	SEE NOTE	GAS VALVE - ANGLED WITH ORIFICE >>> SEE NOTE	3
20	SEE NOTE	ORIFICE - IR ROTISSERIE UNIT (SEE NOTE FOR SIZING)	2
21	SEE NOTE	ORIFICE - SEAR ZONE™ >>> SEE NOTE	1
22	SEE NOTE	ORIFICE - SMOKER UNIT >>> SEE NOTE	1

NOTE: ORIFICE OR VALVE ASSEMBLY TO CHANGE ACCORDING TO FUEL SUPPLY: NATURAL GAS OR LIQUID PROPANE

ITEM	NG GAS	LP GAS
	PART #	PART #
19	290-0310	290-0311
20	220-0285	220-0286
21	220-0289	220-0290
22	220-0313	220-0314

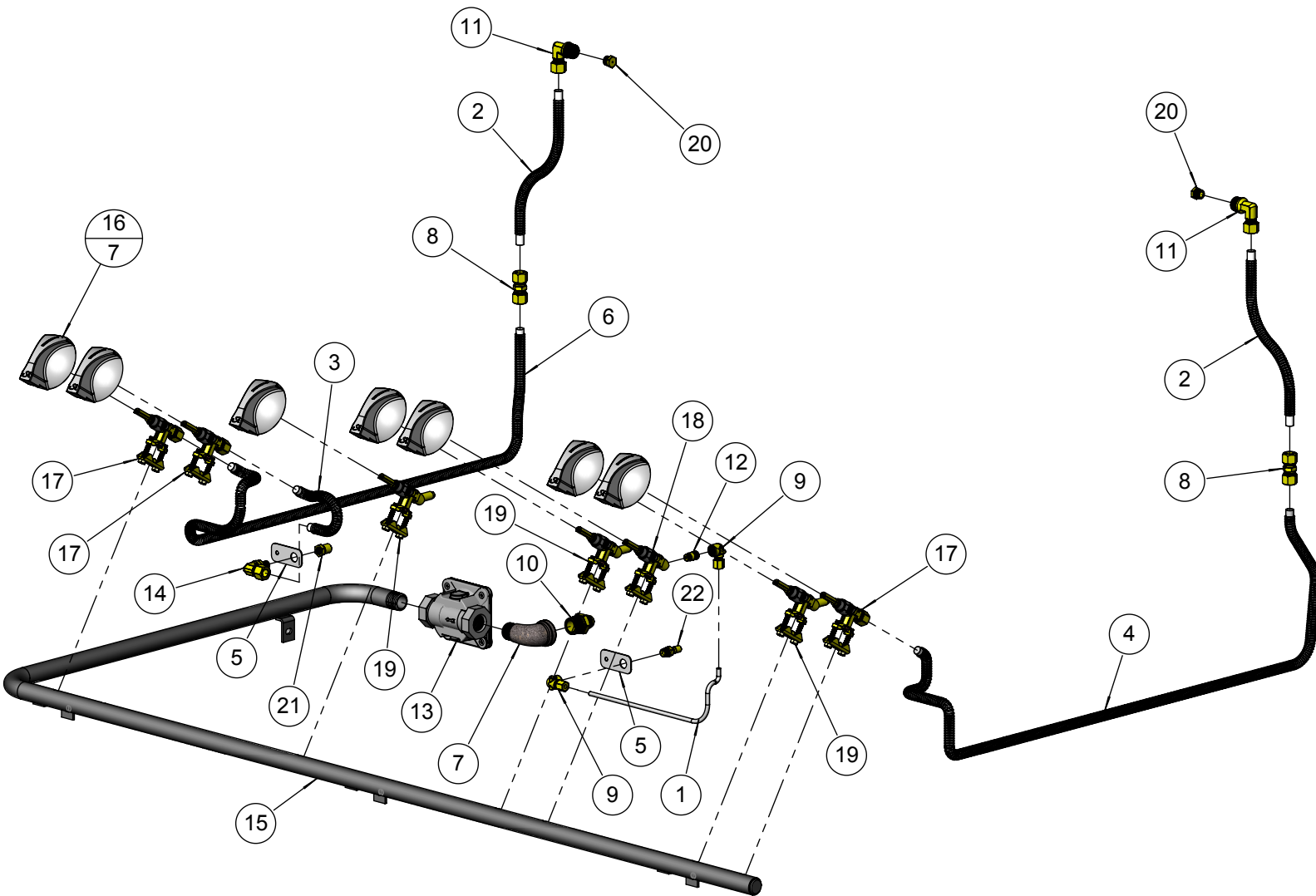

BILL OF MATERIAL

NO.	PART #	DESCRIPTION	QTY
1	100-1986	ALX2-30 / 30SZ - ROTISSERIE BURNER IGNITER BRAKET	1
2	100-1987	ALX2-30 / 30SZ - ROTISSERIE BURNER IGNITER COVER	1
3	200-0111	SCREW 8-18 X 1/2 - SELF TAP - 410 SS	5
4	210-0240	ELECTRODE - DUAL TIP "L" SHAPE- ROTISSERIE	1
5	510-0469	ALX2 - ROTISSERIE PIPING SUBASSEMBLY	1
6	510-0482	ALX2-30 / 30SZ - ROTISSERIE PANEL - WELDED PARTS	1

ELECTRODE SHOWN FOR ASSEMBLY PURPOSES ONLY
REFER TO ASSEMBLY DRAWING 510-0494 FOR ALL
ELECTRICAL COMPONENTS

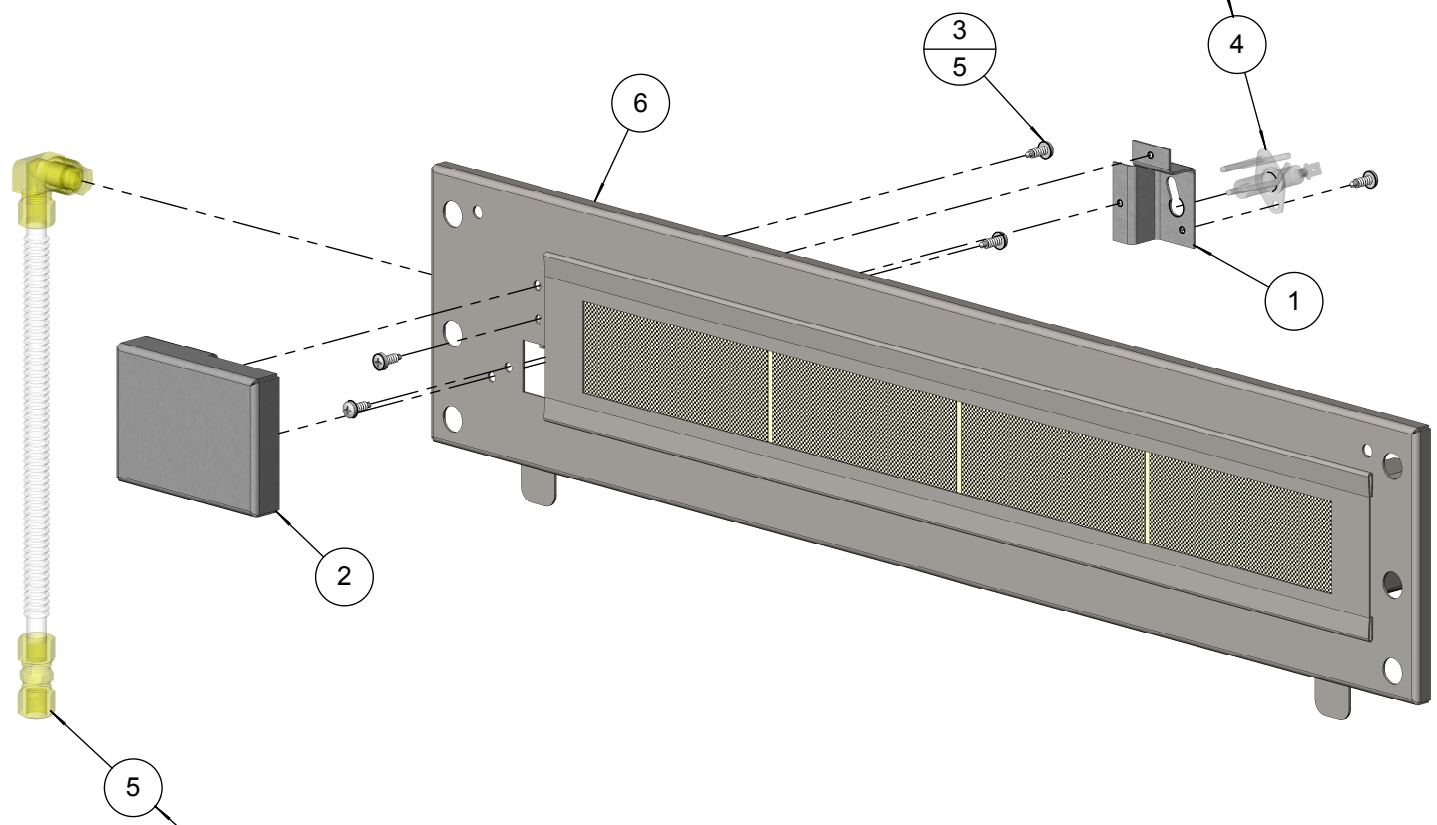

THESE PARTS SHOWN FOR ASSEMBLY PURPOSES ONLY
REFER TO ASSEMBLY DRAWING 510-0465 FOR COMPLETE
PARTS BREAKDOWN AND ORIFICE INFORMATION

BILL OF MATERIALS			
ITEM	PART N°	DESCRIPTION	QTY
1	100-1973	ALX2-30 / 30SZ - GREASE TRAY REMOVABLE PAN	1
2	100-2006	ALX2-56 / 56SZ - GREASE TRAY REMOVABLE PAN	1
3	200-0148	SCREW 10-32 X 3/4" - FLAT HEAD - PHILIPS - 82° - SS	4
4	290-0119	ROLLER WHEEL - STAINLESS STL - 3/4" Ø -	4
5	510-0491	ALX2-56 / 56SZ GREASE TRAY WELDED ASSEMBLY	1

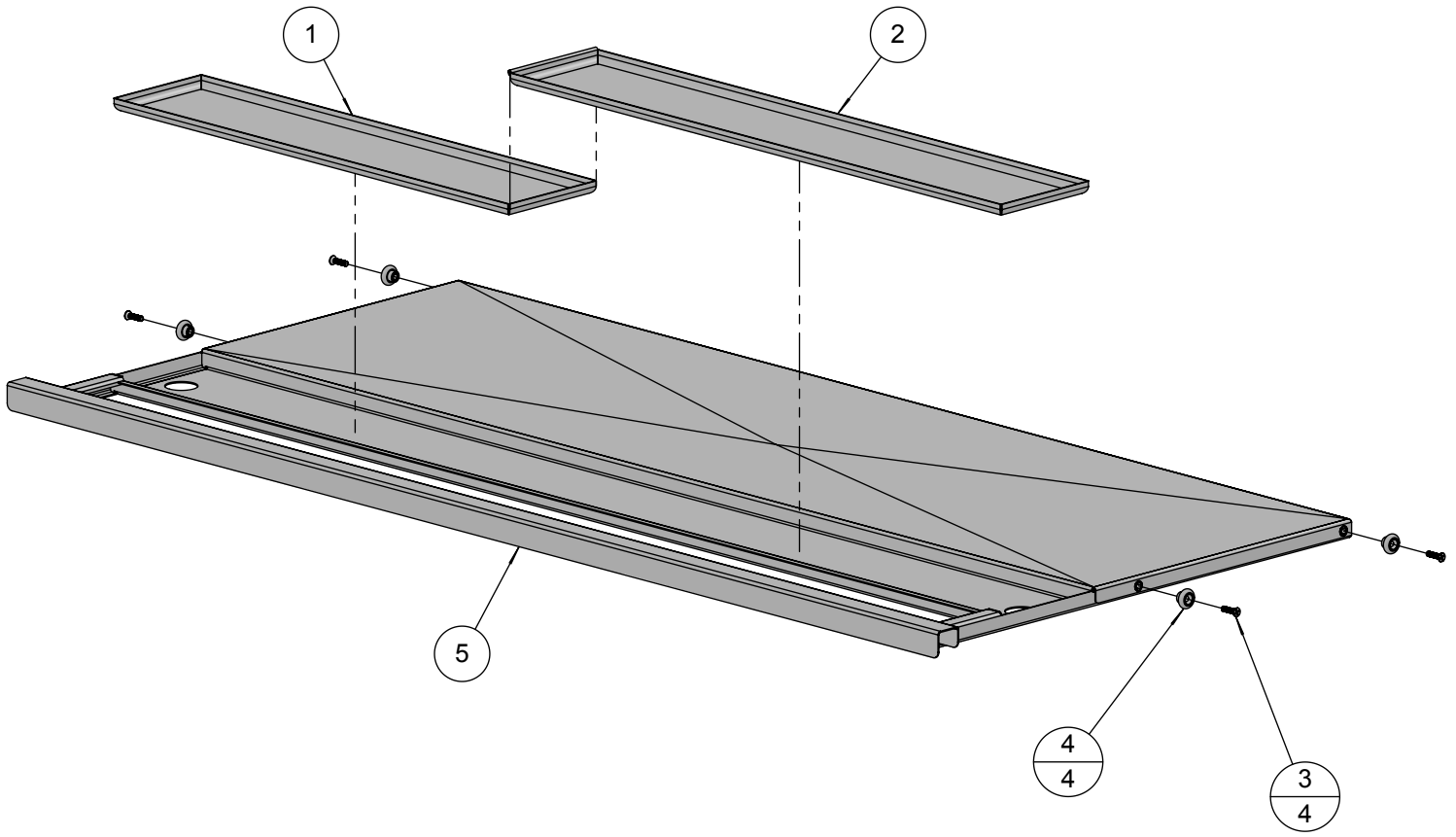

BILL OF MATERIALS			
ITEM	PART N°	DESCRIPTION	QTY
1	210-0189	ELECTRODE - "L" SHAPED - U-BURNER / SMOKER	4
2	210-0192	ELECTRODE - DUAL TIP - SEARZONE™	1
3	210-0198	SWITCH - WEATHER BOOT & CAP	3
4	210-0240	ELECTRODE - DUAL TIP "L" SHAPE- ROTISSERIE	2
5	210-0465	IGNITER MODULE (4 POINTS)	2
6	210-0506	LIGHT SWITCH - [OFF/ ON] TOGGLE	1
7	210-0509	LAMP ASSEMBLY (32" WIRE LENGTH)	1
8	210-0523	ALX2-56 BFG - IGNITER WIRE KIT	1
9	210-0524	ROTISSERIE SWITCH - [OFF/ ON] TOGGLE	1
10	210-0525	IGNITER SWITCH - [OFF/ ON] MOMENTARY	1
11	210-0535	LAMP ASSEMBLY (56" WIRE LENGTH)	1
12	510-0514	ALX2 - ROTISSERIE MOTOR BOX ASSEMBLY	1

REPLACEMENT
ROTISSERIE MOTOR
PART # 210-0235

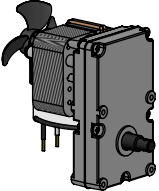

REPLACEMENT LAMP
G940120 - G9 BASE
40W - 120 VAC
PART# 210-0317

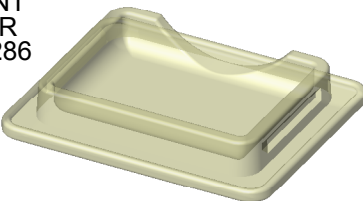
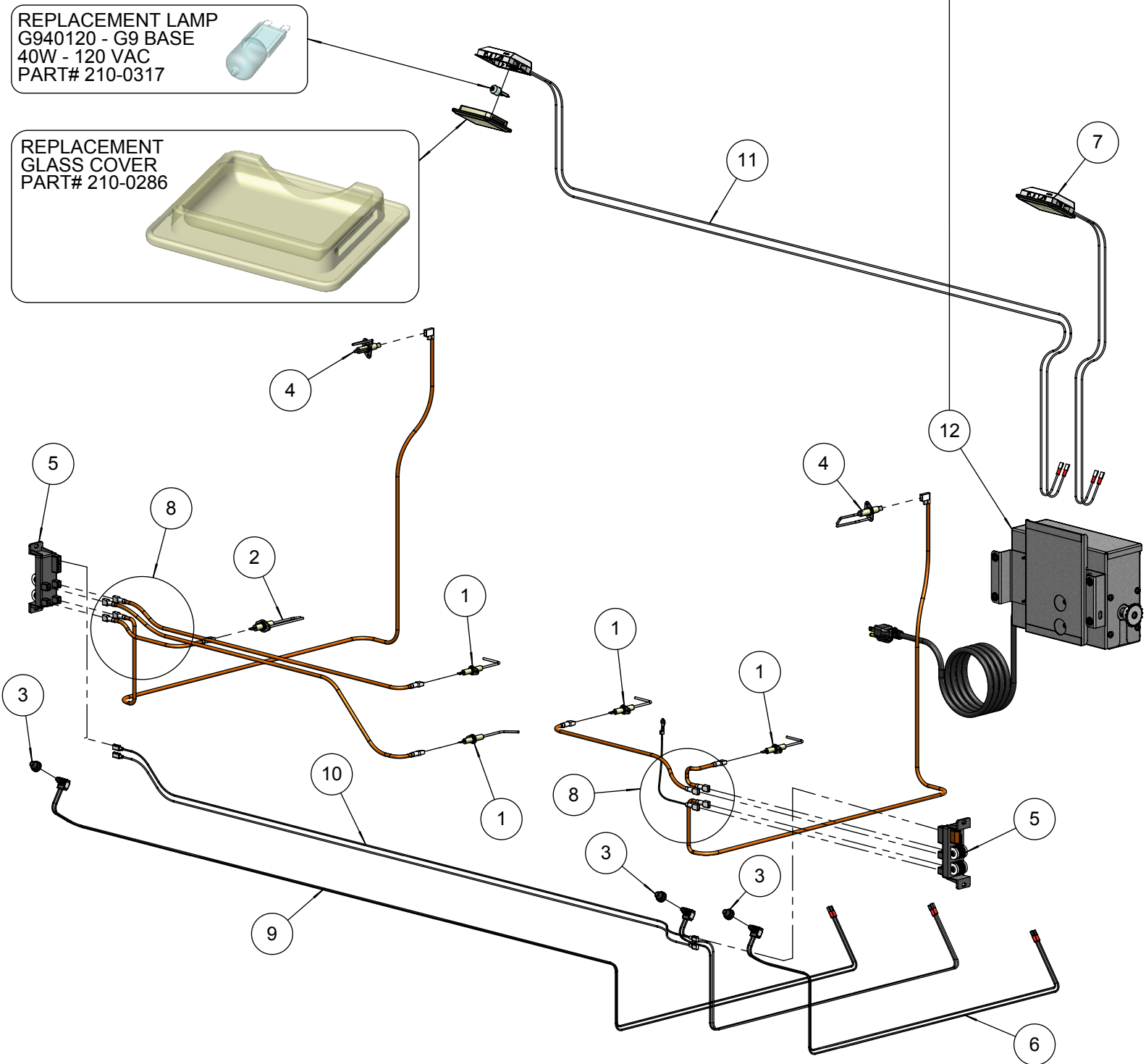

REPLACEMENT
GLASS COVER
PART# 210-0286

BILL OF MATERIAL

NO.	PART #	DESCRIPTION	QTY
1	100-1880	ALX2 - SMOKER TRAY	1
2	100-1881	ALX2 - SMOKER TRAY HANDLE PLATE	1
3	200-0083	8-32 X 1/4 - PAN HEAD - PHILIPS SCREW	2
4	200-0200	WASHER - # 8 - LOCK SPRING - SS	2
5	290-0135	HANDLE - 3/8"Ø X 3" L - TAPPED	1

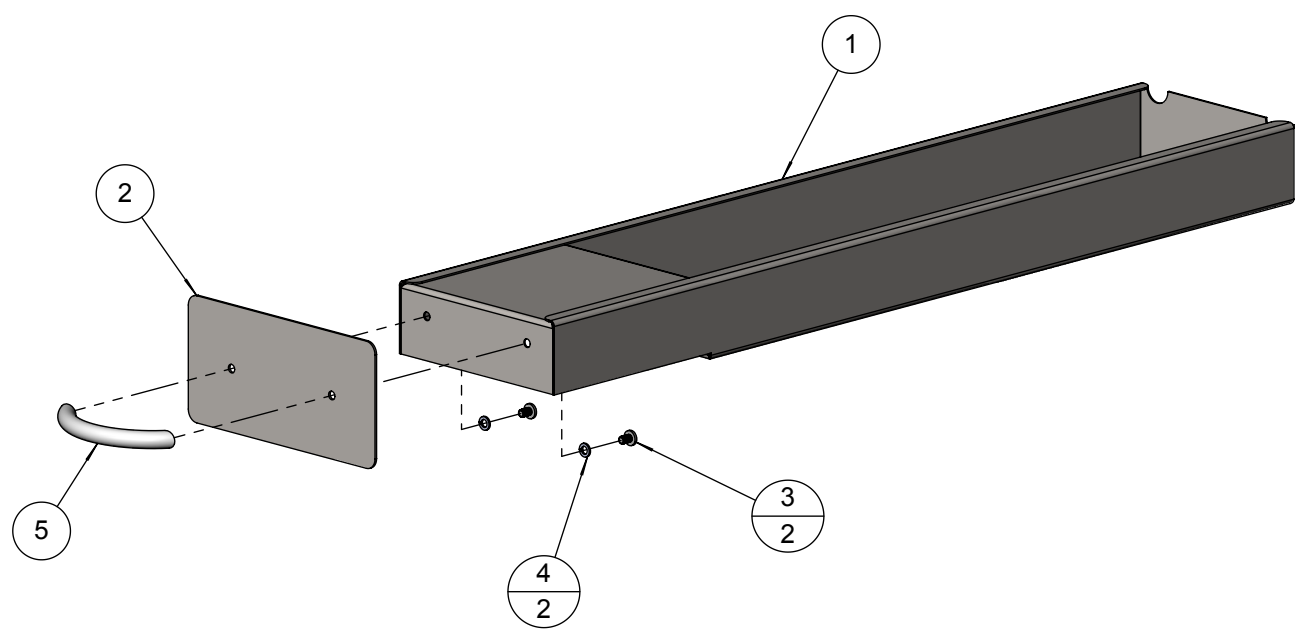

BILL OF MATERIAL

NO.	PART #	DESCRIPTION	QTY
1	100-1895	ALX2 - BRIQUETTE LOCK BAR	3
2	100-1894	ALX2 - BRIQUETTE TRAY BASE	1
3	265-0005	BRIQUETTE - ALFRESCO CUSTOM	24
4	200-0312	SCREW 8-32 x 3/4"- PAN HEAD - PHILIPS - THREAD CUTTER TYPE F	9

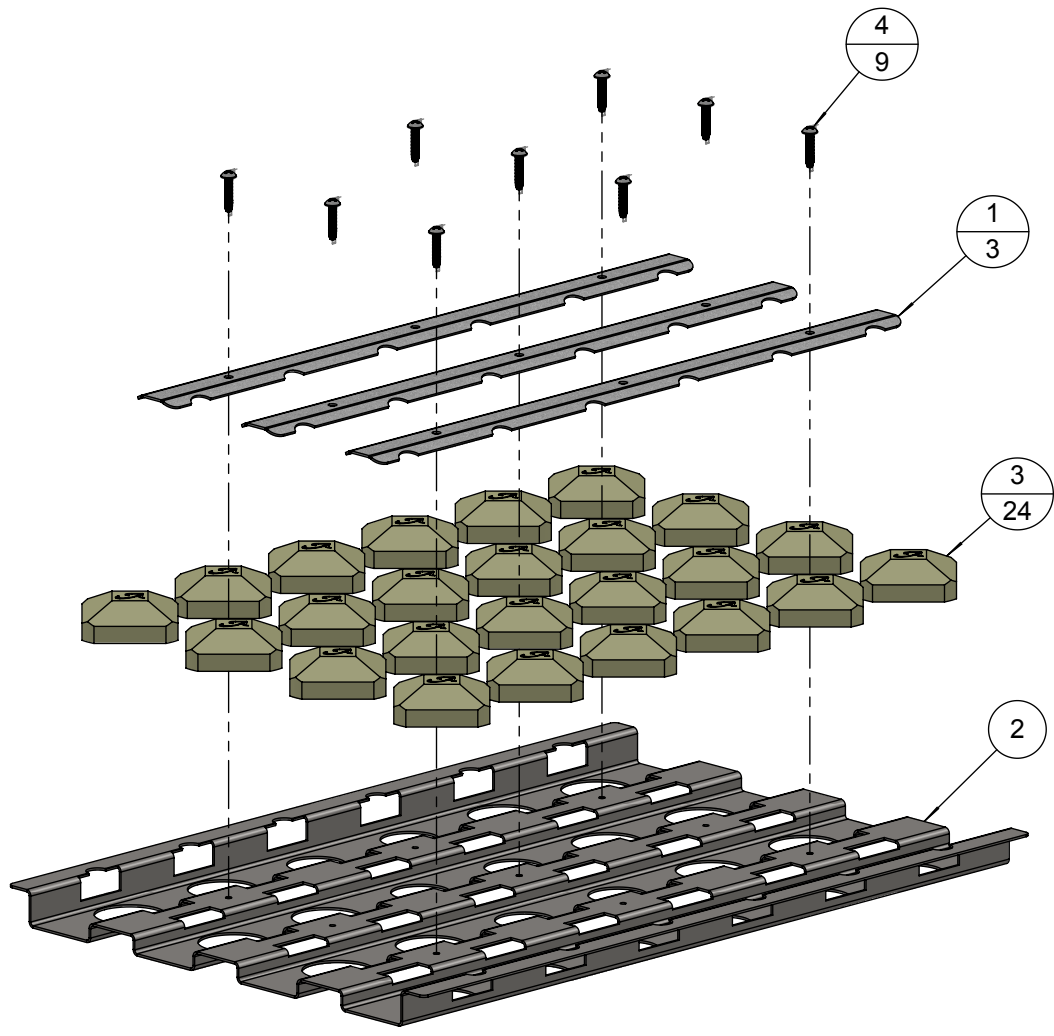

BILL OF MATERIALS

ITEM	PART N°	DESCRIPTION	QTY
1	100-1065	SEARZONE™ OPENING FIREBOX COVER	1
2	100-1201	BFG SEARZONE™ HEAT SHIELD	1
3	100-1833	ALX2 SMOKER BOX TOP DIFUSSER	1
4	100-1846	ALX2 - U-BURNER BRACKET	3
5	100-1847	ALX2 - SEAR-ZONE IGNITER BRACKET / SHIELD	1
6	100-1848	ALX2 - IGNITER SHIELD	3
7	100-1849	ALX2 - IGNITER HOLE COVER	2
8	100-1884	ALX2 - SEAR-ZONE™ BURNER BRACKET	1
9	100-1887	ALX2 - DUAL VALVE FIREWALL COVE	1
10	100-1888	ALX2 - SINGLE VALVE FIREWALL COVE	2
11	100-1946	ALX2 - FIREWALL OPENING COVER FOR U-BURNER	1
12	100-2056	ALX2-56 BFG - SMOKER BOX BODY	1
13	200-0087	WASHER - 1/4" SPRING LOCK- REGULAR - SS	17
14	200-0089	BOLT - HEX HEAD 1/4-20 x 1/2" L	17
15	200-0111	SCREW 8-18 X 1/2 - SELF TAP - 410 SS	45
16	200-0305	SPEED NUT TINNEMAN U-TYPE	1
17	510-0502	ALX2 - GREASE TRAY SUPPORT - RIGHT SIDE	1
18	510-0503	ALX2 - GREASE TRAY SUPPORT - LEFT SIDE	1
19	510-0507	ALX2 - FRONT PANEL BRACKET ASSEMBLY - SINGLE SWITCH	2
20	510-0517	ALX2 - FRONT PANEL BRACKET ASSEMBLY - DUAL SWITCH	1
21	510-0520	ALX2 - FIREWALL SUPPORT BRACKET ASSEMBLY	2
22	510-0542	ALX2-56BFG - FIREWALL ASSEMBLY	1
23	510-0543	ALX2-56BFG FIREBOX - WELDED PARTS	1

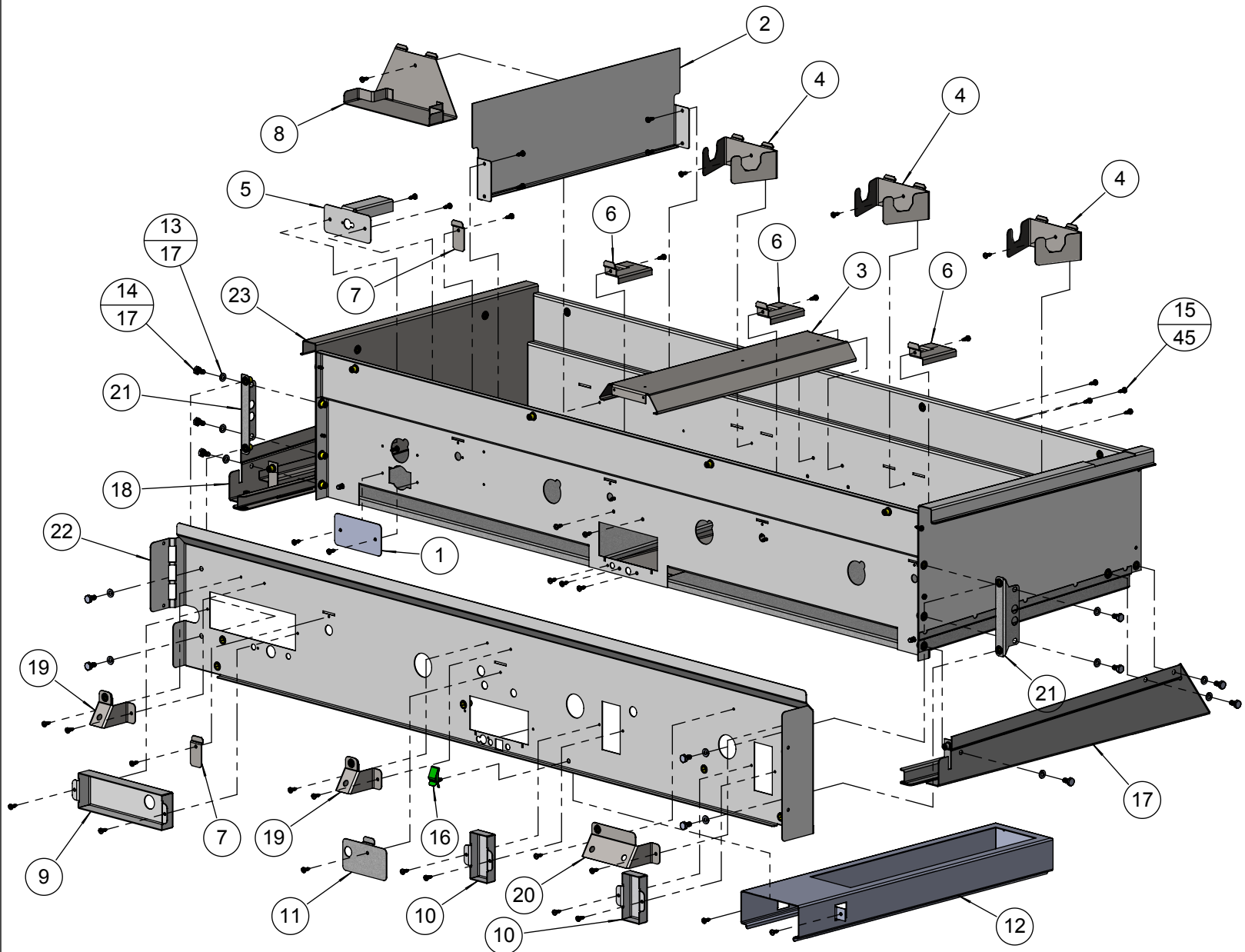

BILL OF MATERIALS

ITEM	PART N°	DESCRIPTION	QTY
1	100-1092	ALX2 - ROTISSERIE GEAR COVER	1
2	200-0065	SCREW 1/4-20 x 1-1/4" - SS - HEX HEAD	2
3	200-0079	8-32 X 3/4 - PAN HEAD - PHILIPS SCREW	4
4	200-0086	1/4-20 X 3/8 - TRUSS HEAD - PHILIPS SCREW	2
5	200-0087	WASHER - 1/4" SPRING LOCK- REGULAR - SS	8
6	200-0089	BOLT - HEX HEAD 1/4-20 x 1/2" L	4
7	200-0090	1/4-20 - DOUBLE CHAMFER - HEX NUT	2
8	200-0092	1/4 X 1/8 X 5/8 FLAT WASHER - SPACER	2
9	200-0111	SCREW 8-18 X 1/2 - SELF TAP - 410 SS	1
10	200-0148	SCREW 10-32 X 3/4" - FLAT HEAD - PHILIPS - 82° - SS	2
11	200-0305	SPEED NUT TINNEMAN U-TYPE	6
12	290-0119	ROLLER WHEEL - STAINLESS STL - 3/4" Ø -	2
13	510-0139	ALX2 - ROTISSERIE GEAR ASSEMBLY	1
14	510-0478	ALX2-30 / 30SZ - ROTISSERIE PANEL ASSY	1
15	510-0483	ALX2-30 / 30SZ - WARMING RACK BRACKET - RT SIDE	2
16	510-0484	ALX2-30 / 30SZ - WARMING RACK BRACKET-LT SIDE	2
17	510-0583	ALX2-56 BFG BACK HOOD AND RIM - WELDED PARTS	1
18	510-0584	ALX2-56 BFG ROTISSERIE PANEL - RIGHT SIDE	1

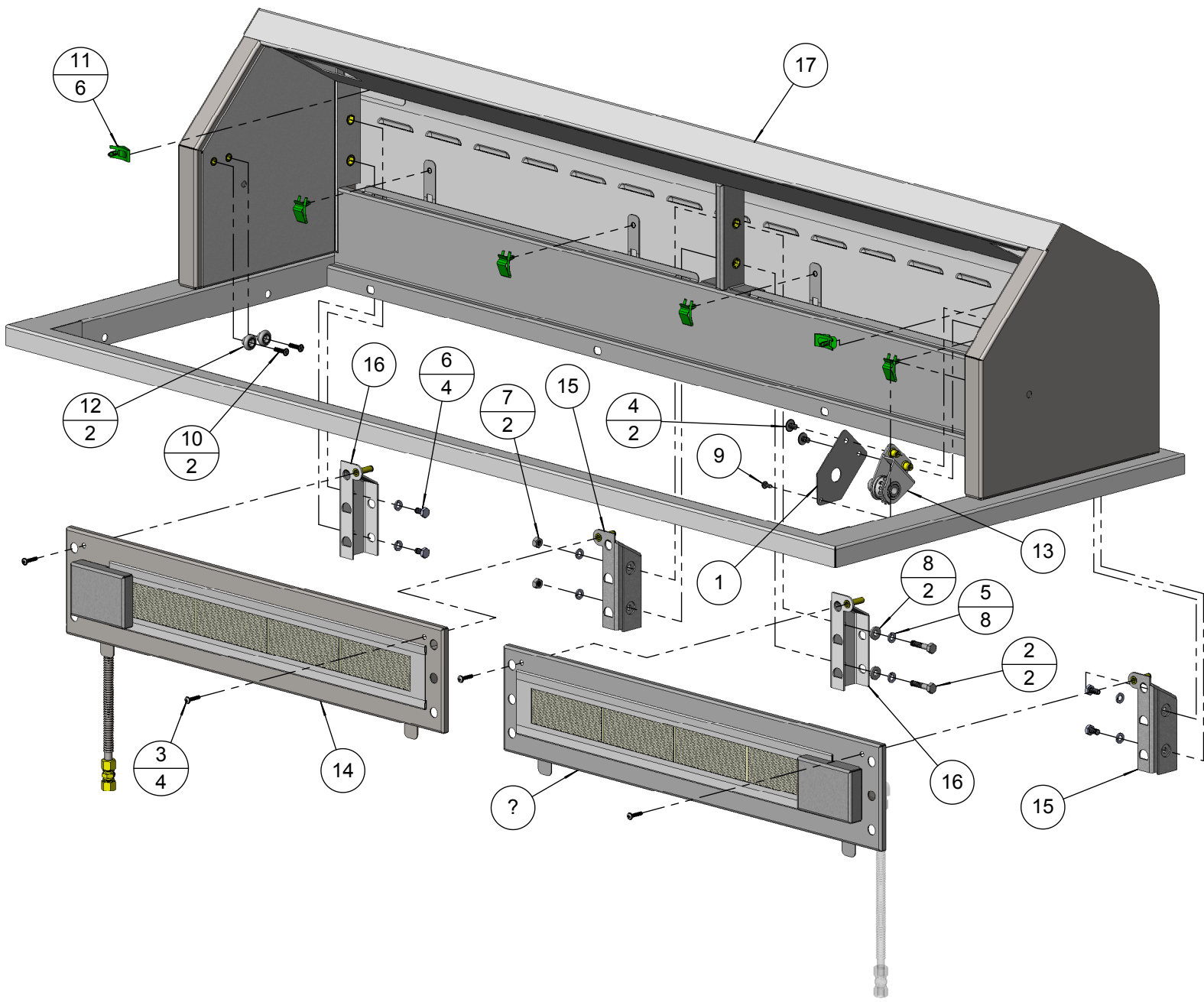

BILL OF MATERIALS

ITEM	PART N°	DESCRIPTION	QTY
1	100-1986	ALX2-30 / 30SZ - ROTISSERIE BURNER IGNITER BRAKET	1
2	100-1987	ALX2-30 / 30SZ - ROTISSERIE BURNER IGNITER COVER	1
3	200-0111	SCREW 8-18 X ½ - SELF TAP - 410 SS	5
4	210-0240	ELECTRODE - DUAL TIP "L" SHAPE- ROTISSERIE	1
5	510-0469	ALX2 - ROTISSERIE PIPING SUBASSEMBLY	1
6	510-0544	ALX2-56BFG ROTISSERIE PANEL - WELDED PARTS	1

ELECTRODE SHOWN FOR ASSEMBLY PURPOSES ONLY
REFER TO ASSEMBLY DRAWING 510-0497 FOR ALL
ELECTRICAL COMPONENTS

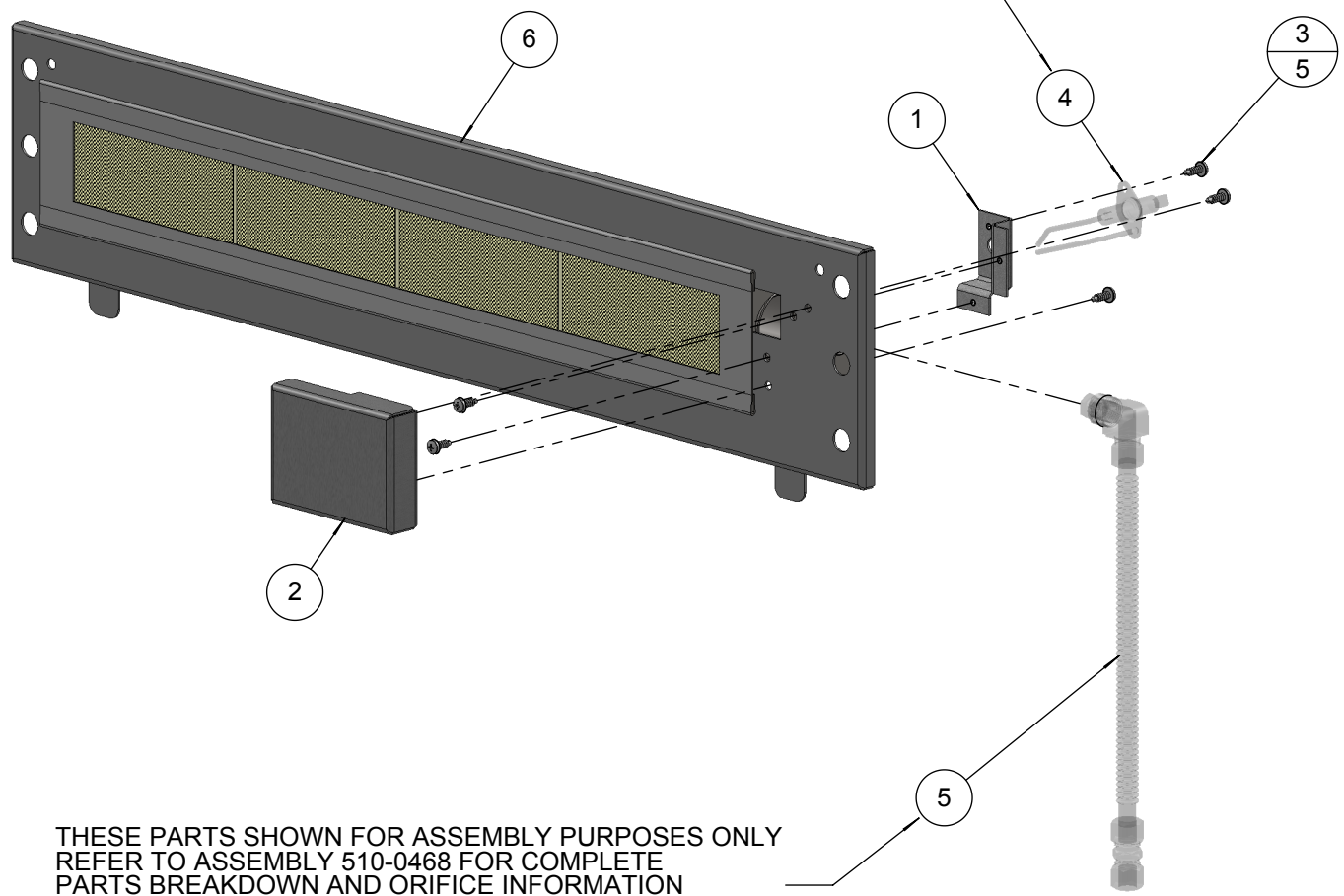

THESE PARTS SHOWN FOR ASSEMBLY PURPOSES ONLY
REFER TO ASSEMBLY 510-0468 FOR COMPLETE
PARTS BREAKDOWN AND ORIFICE INFORMATION

BILL OF MATERIALS			
ITEM	PART N°	DESCRIPTION	QTY
1	100-1873	ALX2 - FRONT HOOD PIVOT SLEEVE	2
2	200-0087	1/4" LOCK WASHER	4
3	200-0091	HH- HD - 1/4-20 x 1 x .75 THREAD	4
4	200-0165	SCREW 1/4-20 X 1 1/4 - TRUSS HEAD - PHILIPS - 410 SS	2
5	210-0418	ALFRESCO - 3-1/8"Ø - ALX2 THERMOMETER	1
6	290-0063	HANDLE - END CAP ASSEMBLY	2
7	290-0089	HANDLE BAR - 50" SMOOTH	1
8	510-0586	ALX2-56 BFG FRONT HOOD - WELDED PARTS	1

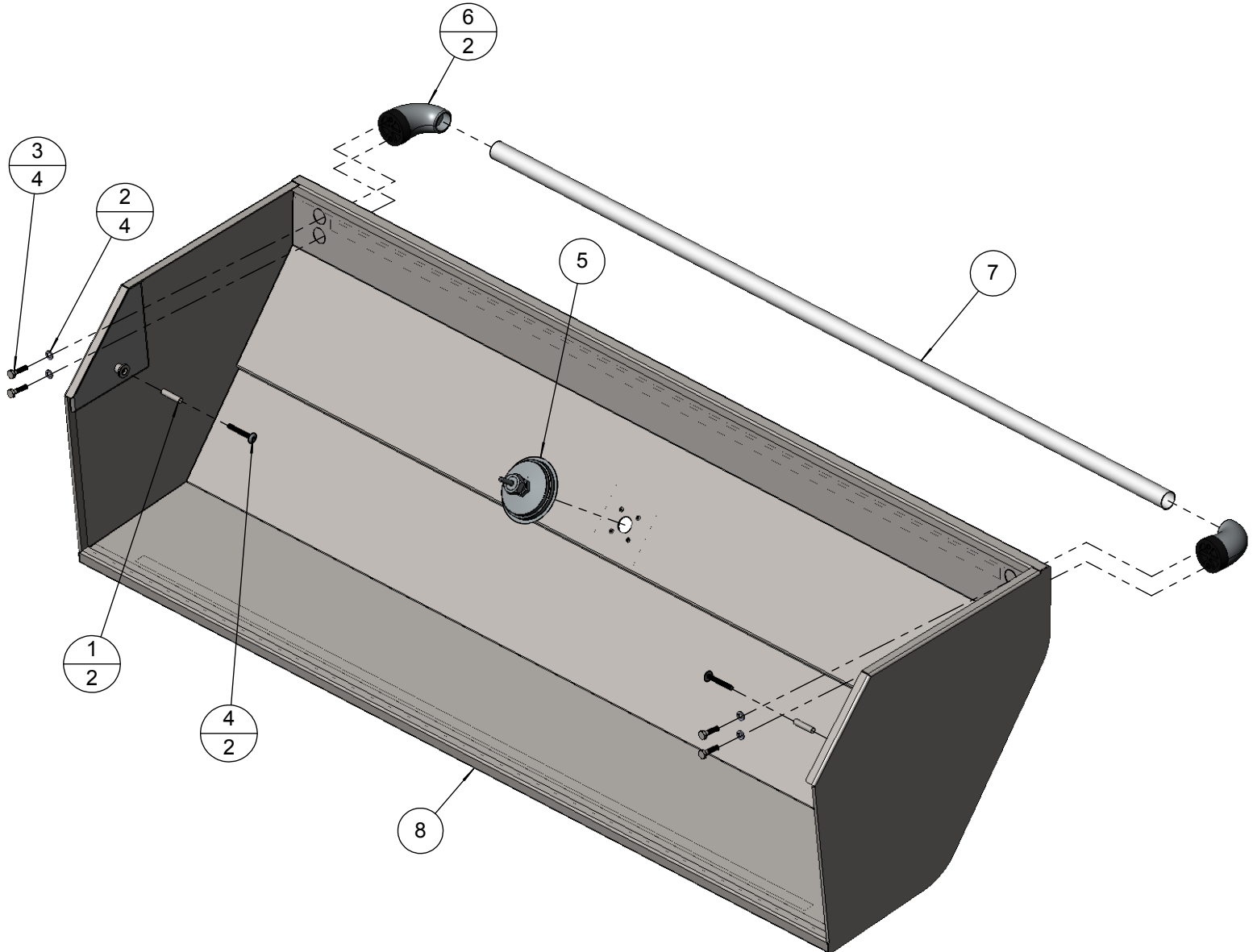

TM

Alfresco

Open Air Culinary Systems

ALX2 • PARTS MANUAL
ALFRESCO™ GOURMET GRILLS
ALL RIGHTS RESERVED • 08/2011