



AXE-PZA WITH BIA UNIT

AXE-30 ACCESS DOOR (OPTIONAL SEE PAGE 2)

AXE-PZA AND "BI" TYPICAL UNIT INSTALLED WITH A FULL FASCIA BRICK WALL DESIGN

Due to the unique design of the *Alfresco*™ Pizza Oven, the unit can be piped from behind or below as it might be required by a custom installation and finish. Both locations are shown here as an aid in design only.

For additional information, please refer to the AXE-PZA Care and Use manual.

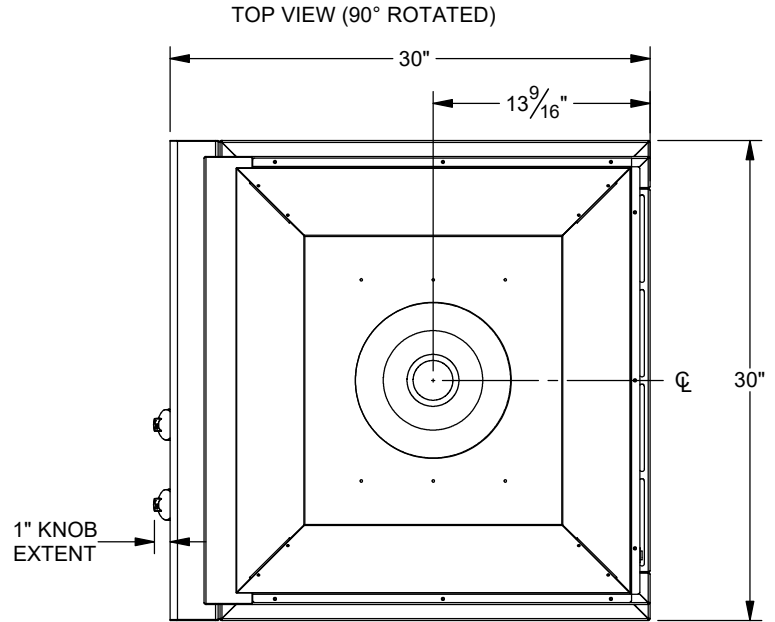

FRONT VIEW

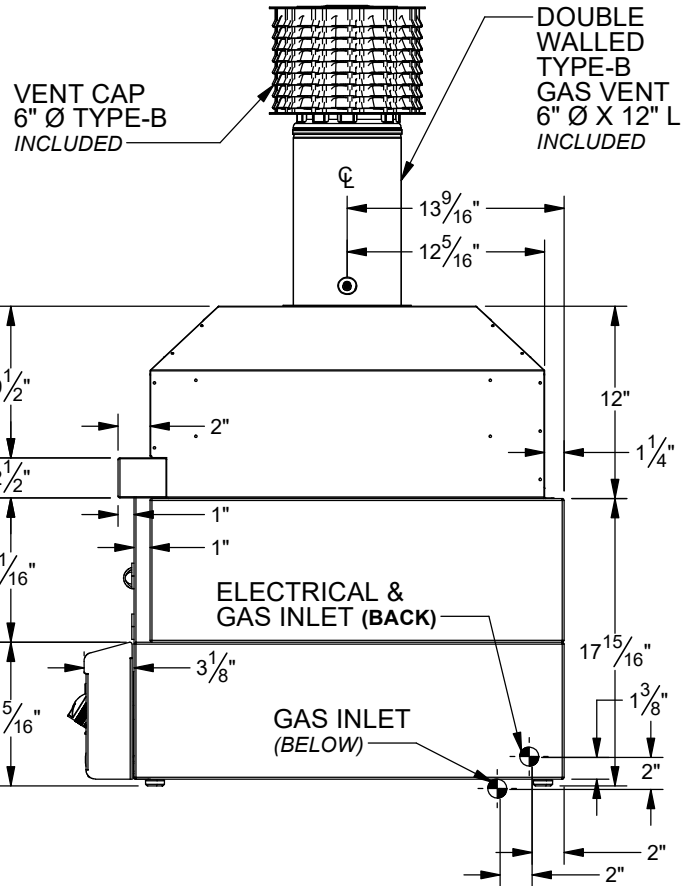
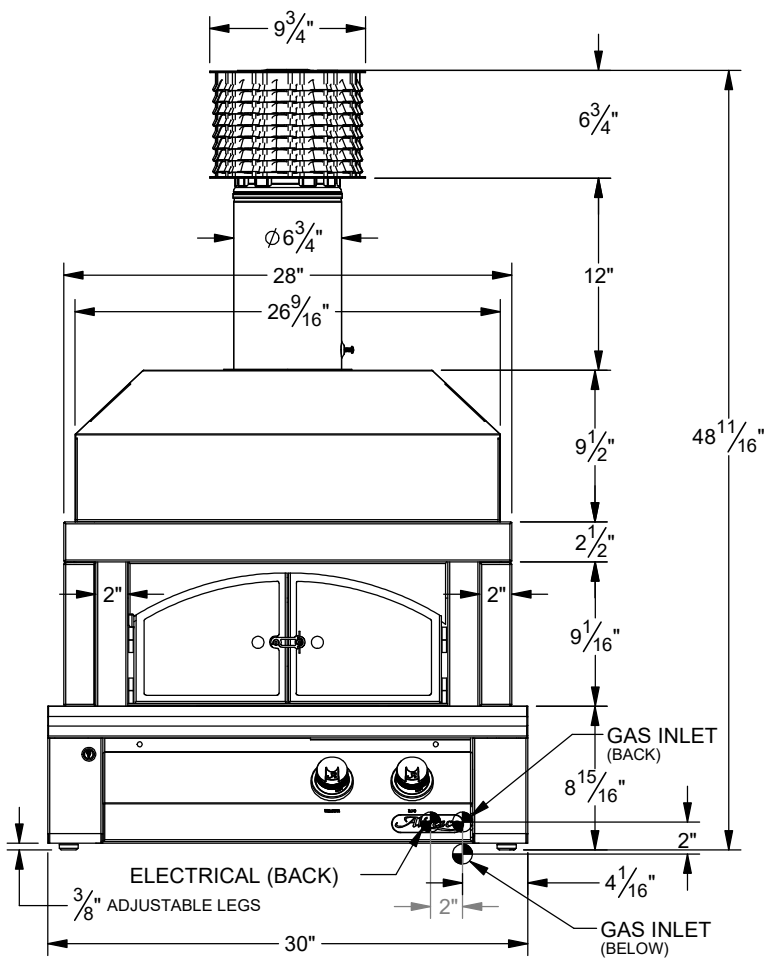

When installing the *Alfresco*™ Pizza Oven as a built-in unit, careful consideration to the materials used must be made. As a general rule, the materials and construction methods should be the same as the requirements for an outdoor fireplace while maintaining all local building codes.

**Dimensions shown below should be used as a reference for design and planning only.**

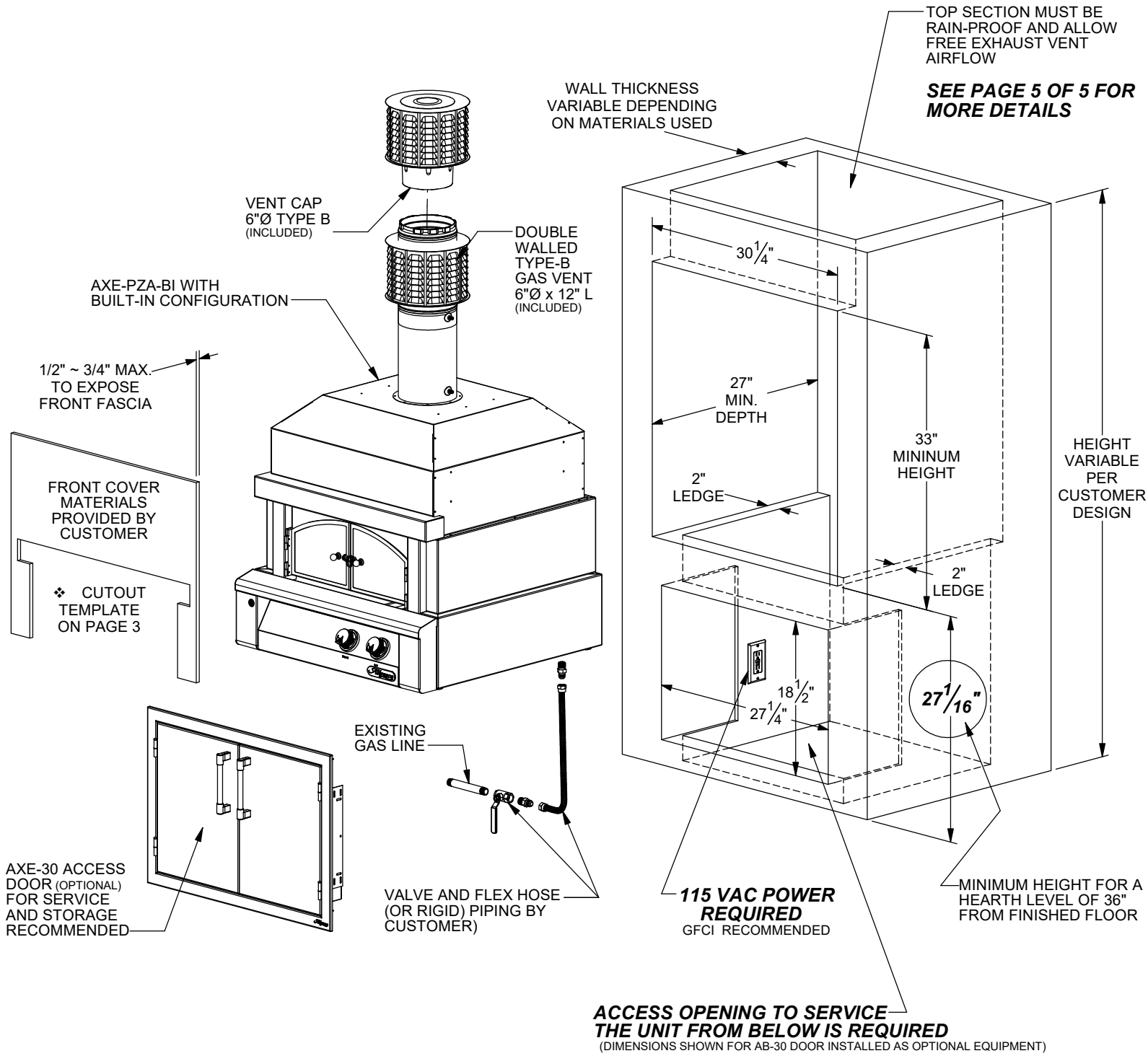

**SPECIFICATIONS:**

BTUH = 35,600  
 FUEL NG @ 5 W.C. / LP @ 10 W.C.  
 ELECTRICAL POWER: 115 VAC / 0.3 A / 60 Hz.  
 GAS CONNECTION = 1/2" NPT (NG) OR 3/8" ODF (LP)

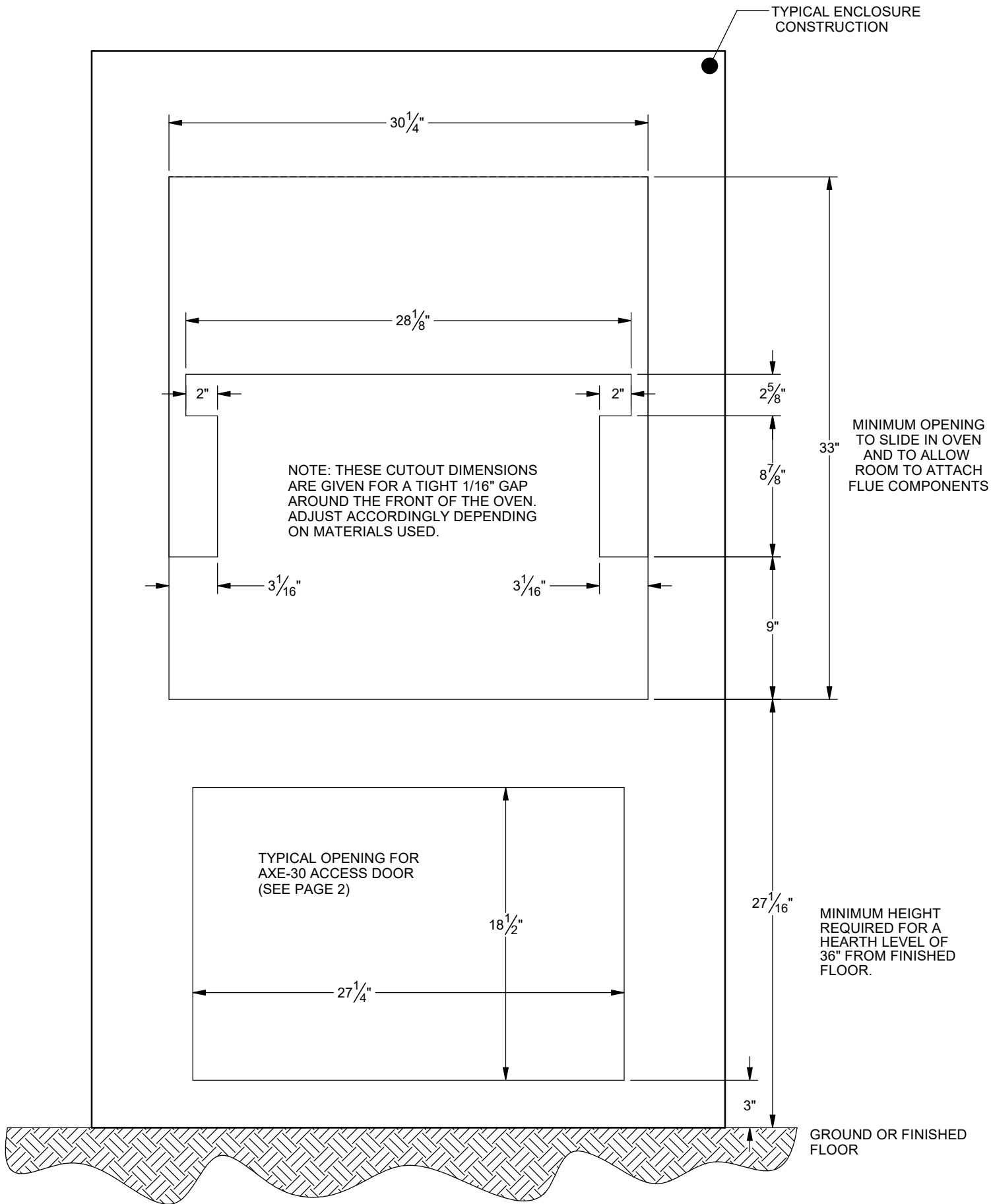

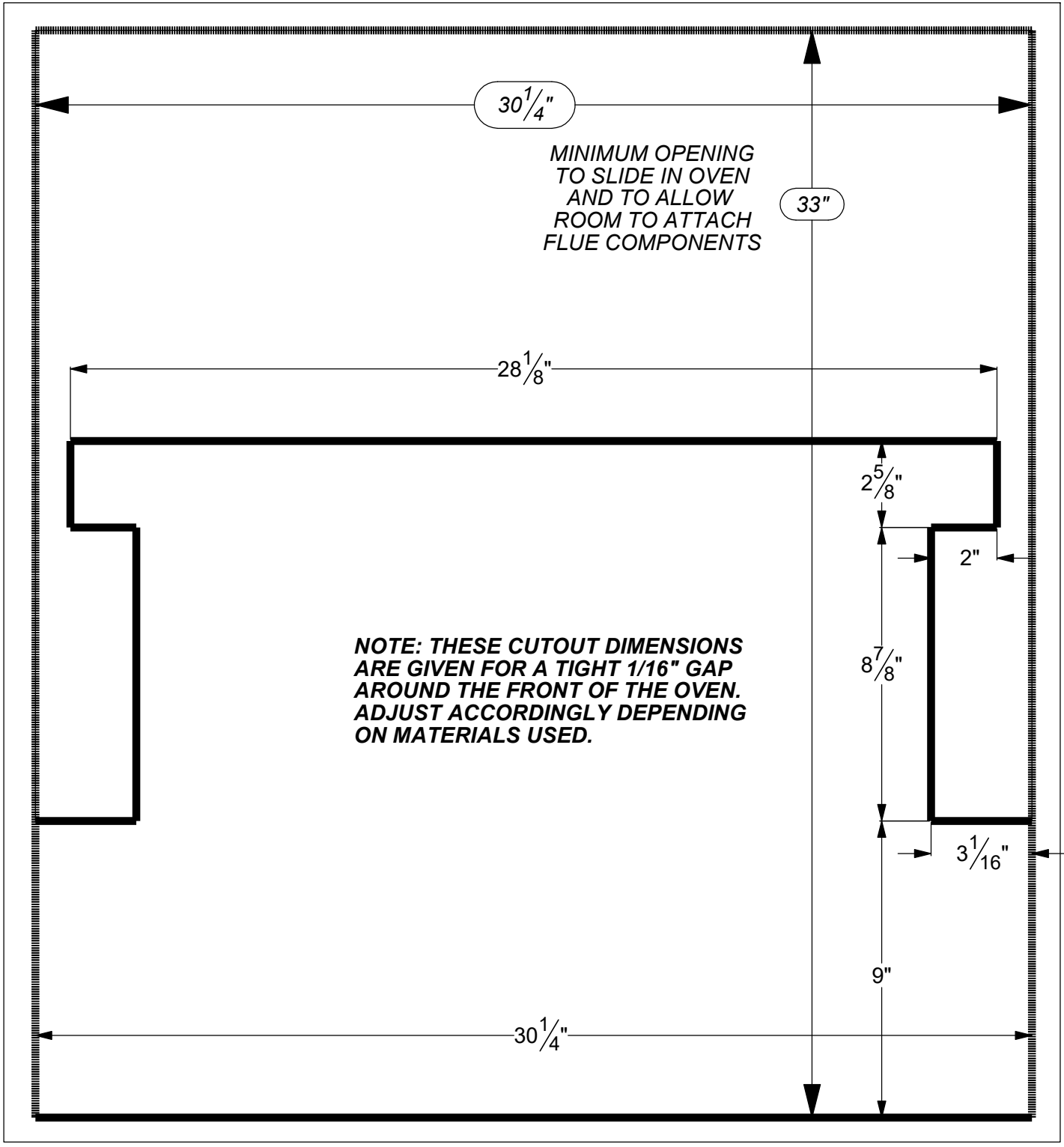

**FULL SIZE TEMPLATE**



ROOFING MATERIALS AND FINISH AS APPROVED BY LOCAL CODES

GAS VENT CAP TYPE-B (INCLUDED) OR SIMILAR AS PER LOCAL CODES

TYPICAL EXHAUST VENT TYPE-B EXTENSION

MINIMUM HEIGHT AS PER LOCAL CODES

STORM COLLAR IF REQUIRED BY LOCAL CODES

10 FT. MAXIMUM EXHAUST LENGTH FOR OPTIMAL OVEN OPERATION

ROOF FLASHING AS REQUIRED BY LOCAL CODE

THROUGH WALL INSTALLATION

DEDUCT 2 FT. EXHAUST LENGTH PER EACH ELBOW

GAS VENT CAP TYPE-B (INCLUDED)

STANDARD 6"Ø X 12" H TYPE-B (INCLUDED)

STORM COLLAR AS REQUIRED BY LOCAL CODES

AXE-PZA-BI UNIT

**NOTE:**  
Additional consideration must be made to ventilation under the unit. The construction below the Pizza oven must have proper air circulation in order to have proper gas combustion. The bottom section of the built-in enclosure must have a minimum of 1 Sq.Ft. of standard building construction vents to provide ample air circulation.

NON-COMBUSTIBLE CONSTRUCTION

AXE-30 ACCESS DOOR RECOMMENDED

SECTION A-A  
SCALE 1 : 14