

GAS TANK SHOWN AS REFERENCE (CUSTOMER SUPPLIED)

SPECIFICATIONS:

BTUH: 75,000
 FUEL: NG @ 5" W.C. OR LP @ 10" W.C.
 ELECTRICAL POWER: 115 VAC / 0.71 AMPS / 60 Hz.
 GAS CONNECTION: 1/2" NPT (NG) OR 3/8" ODF (LP)

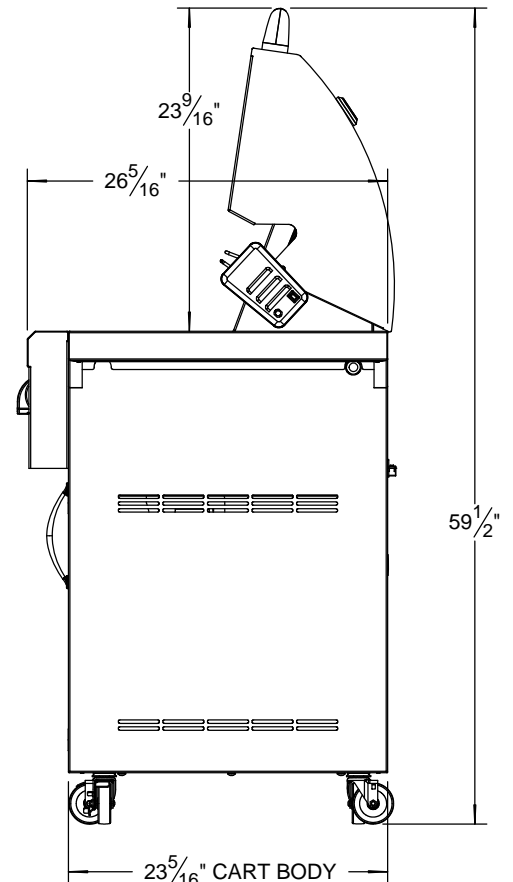
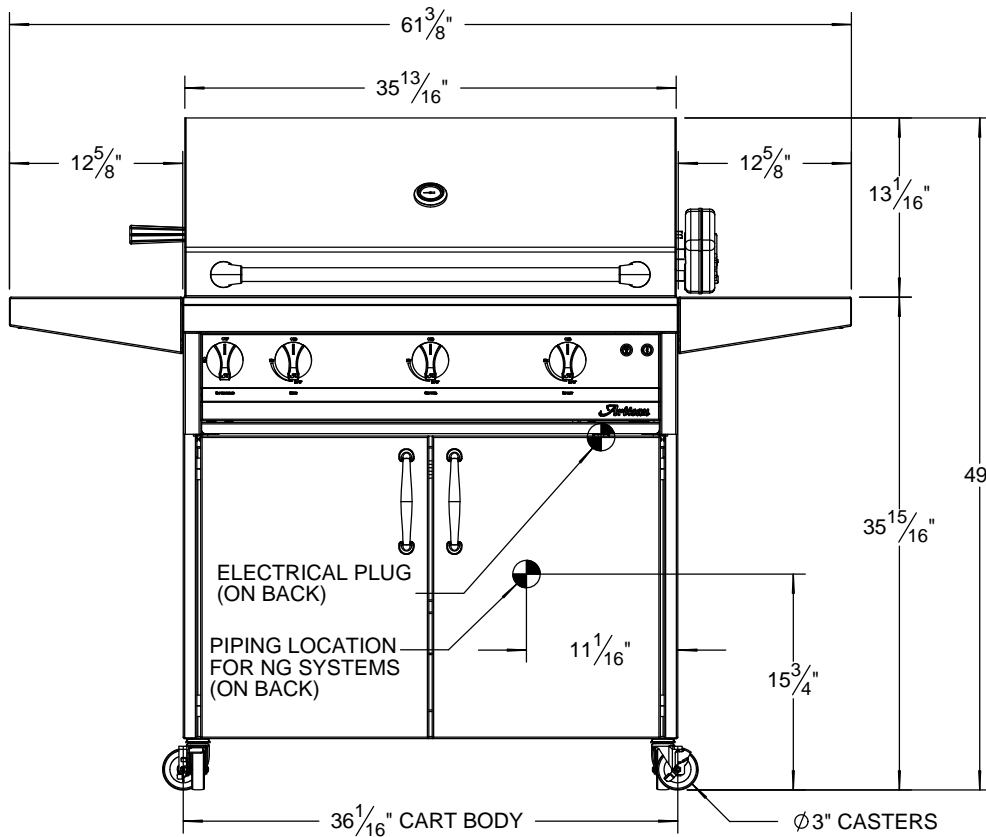

Artisan

SUPERIOR EQUIPMENT SOLUTIONS
 7039 EAST SLAUSON AVENUE
 COMMERCE, CA. 90040

THE INFORMATION CONTAINED IN THIS DRAWING IS THE SOLE PROPERTY OF SUPERIOR EQUIPMENT SOLUTIONS INC. ANY REPRODUCTION IN PART OR AS A WHOLE WITHOUT WRITTEN PERMISSION FROM SUPERIOR EQUIPMENT SOLUTIONS, INC. IS PROHIBITED.

DRAWN BY: Jorge Pelayo
CREATED: Tuesday, March 08, 2016

PROJECT TITLE:
ARTISAN GRILLS

DRAWING TITLE:

DRAWING NO.:
ARTP-36C SPEC SHEET